



EN

## Compact wheel balancer with digital display

Conceived for mobile wheel service units or usage where space is limited:

- Manual spin (no motor)
- Lever operated clamping brake to facilitate wheel clamping and unclamping
- 11 balancing programmes for steel and alloy passenger car, van and motorcycle wheels
- Complete with special OPT and HIDDEN WEIGHT programmes
- May also operate with 12 Volt power source (\*)

FR

## Équilibreuse compacte à écran numérique

Conçue pour le service mobile ou en cas de problème de place:

- Lancement manuel (sans moteur)
- Frein de stationnement par levier pour faciliter le blocage et le déblocage de la roue
- 11 programmes d'équilibrage pour jantes en acier et en alliage, pour voitures, utilitaires légers et motos.
- Programmes OPT et MASSE CACHÉE disponibles
- Peut aussi travailler à 12 Volt (\*)

ES

## Equilibradora compacta con pantalla digital

Ideal para el servicio móvil o para quienes tienen problemas de espacio:

- Lanzamiento manual (sin motor)
- Freno de estacionamiento con palanca para facilitar las operaciones de bloqueo y desbloqueo de la rueda
- 11 programas de equilibrio para ruedas de acero y de aleación de automóviles, furgonetas y motos
- Incluye los programas especiales: OPT y PESO OCULTO
- Funciona incluso con 12 V (\*)

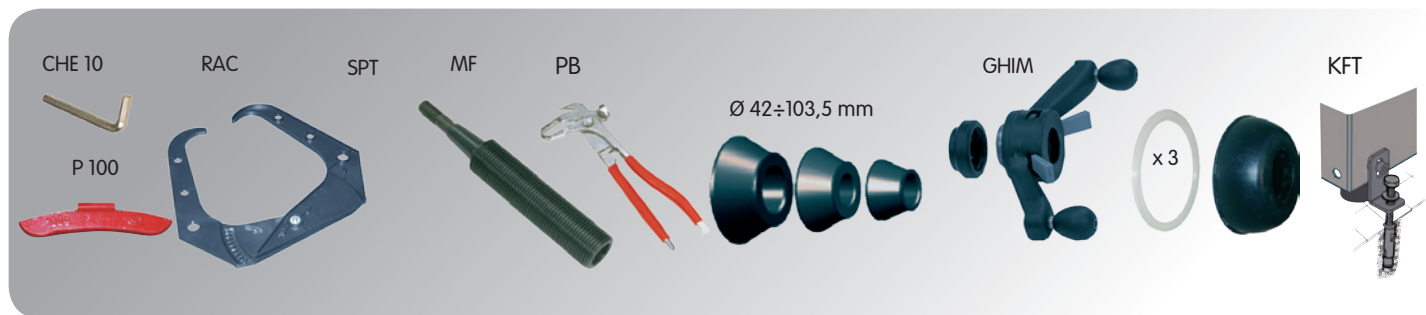

EN → Recommended accessories FR → Accessoires conseilles ES → Accesorios recomendados

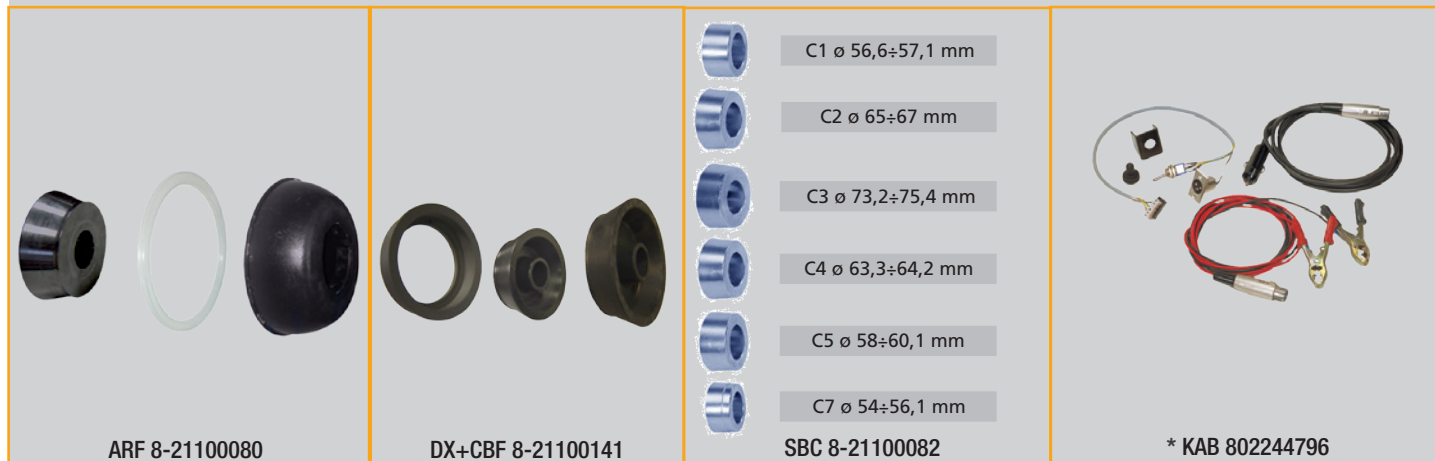

- EN → •ARF Accessory for off-road wheels  $\varnothing$  102,5÷118,5 mm •DX+CBF Double front cone with spacer  $\varnothing$  117-173 mm •SBC Set of rear centring bushes  $\varnothing$  40 •KAB External battery power kit (12V)
- FR → •ARF Accessoire de centrage arrière pour véhicule tout-terrain  $\varnothing$  102,5 mm ÷118,5mm •DX+CBF Double cône de centrage avec entretoise  $\varnothing$  117-173 mm •SBC Kit de bagues de centrage •KAB Cable de branchement de batterie (12V)
- ES → •ARF Accesorios para el centrado trasero de los vehículo todo terreno  $\varnothing$  102,5 mm ÷118,5mm •DX+CBF Cono bifronte  $\varnothing$  117-173 mm con separador •SBC Serie casquillos de centrado trasero  $\varnothing$ 40 •KAB Kit de alimentación de batería externa (12V)

EN → Dimensions FR → Dimensions ES → Dimensiones

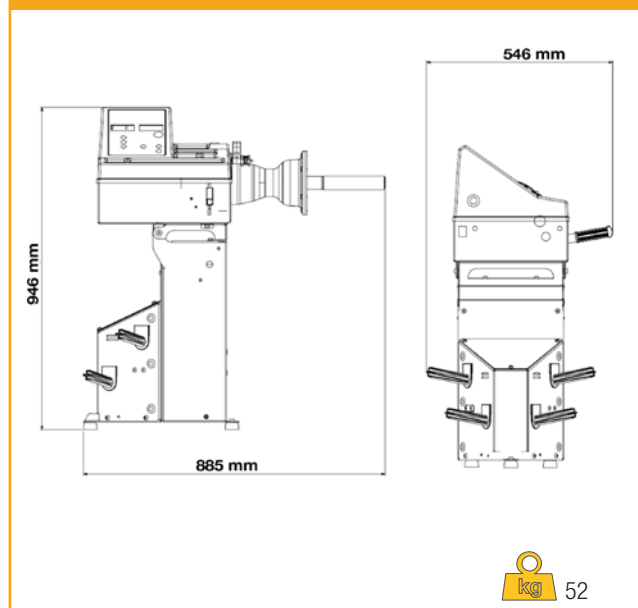

EN → Technical Data FR → Données techniques ES → Datos técnicos

	115/230V 1Ph - 50/60Hz *KAB kit=12 Volt		1,5" - 20"
	900 mm		1" ÷24" (ALU) 1" ÷35"
	500 mm		65 kg

- A Standard RAL 1007
- B Optional RAL 3002
- C Optional RAL 5015
- D Optional RAL 9006

- EN → Main frame is always dark grey RAL 7016
- FR → Couleur du châssis principal: toujours gris lancé RAL 7016
- ES → Marco principal es siempre de color gris oscuro RAL 7016

Descrizioni ed immagini non impegnative. La SICE si riserva di apportare modifiche in qualsiasi momento e senza preavviso. Descriptions and drawings not binding. SICE reserves the right to modify its machines at any time without prior notice. Cod. DPSC000152\_Ed. 11/2014



Società Italiana Costruzioni Elettromeccaniche - S.I.C.E. SpA  
via Modena, 34 - 42015 Correggio RE - Italy  
Tel. +39 0522 693640 - Fax +39 0522 642882 [www.sice.it](http://www.sice.it) - [sice@sice.it](mailto:sice@sice.it)

