

5,000 stocked consumables

AUTO4

EQUIPPING THE TYRE INDUSTRY



NEXT DAY DELIVERY*

OUR PRICE PROMISE

£ £ £

If you find the same product cheaper elsewhere we will refund the difference! **

AUTOMOTIVE EQUIPMENT, TOOLS AND CONSUMABLES

Always the best products at the best possible prices

Orderline : 0845 0770 190

Lines Open: 8.30am - 5.00pm Monday - Friday or Email: sales@auto4.co.uk

or buy online at : www.auto4.co.uk

ISSUE 5



EQUIPPING THE TYRE INDUSTRY



Supplying professional brands at competitive prices to the automotive market.

We are Auto4



Massive range of products



Very high stock availability



Competitive prices with price guarantee



Free same or next day delivery



Trade accounts available



High quality products



Flexible ways to buy from us



Experts, not order takers

Exceptional Auto4 Service

Auto4 has been serving the automotive industry for over forty years and has been successful during this time because we consistently put our customers at the heart of our business. To ensure we don't let you down we;

- employ and invest in expert staff not just order takers, this way we really can help you solve your problems
- have in stock over 5,000 product lines, which in the vast majority of cases are delivered to you on a same or next day service
- employ an in-house engineering team dedicated to keeping your equipment and therefore your business working
- have products and prices to suit all pockets, which means whether you want the very best quality or low cost we have the right item in stock
- test all of our products to ensure they are fit for purpose and won't let you down
- offer different ways to buy from us, so whether you want a van to call, or to simply trade on line the option is available, its your choice



AUTO4

EQUIPPING THE TYRE INDUSTRY

More products,
latest offers, great value
and fast delivery...



www.auto4.co.uk

The Auto4 website offers you our customer the convenience of being able to order products at a time to suit you; it offers you the ease of being able to find what you are looking for quickly and purchase it within just a few clicks; and it improves ordering accuracy with detailed technical descriptions and photographs which mean you get what you want first time.

If you are an existing account customer the website is designed to complement and enhance your current method of trading with us. If you aren't yet a customer then perhaps the website will become your preferred method of trading. Whatever your decision once you have an account with Auto4, whether you want to trade with a field sales representative, telesales or the website, our systems are flexible enough to meet your needs.

Just some of the Auto4 website features;

- existing account holders can log in, access their own pricing and order products on their account
- non customers can sign up for a new account and subsequently order products
- account holders can 'manage' their account, reviewing previous orders and printing copies of invoices and statements
- account holders can gain access to worthwhile down loads, including equipment parts diagrams, MSDS/ COSHH Data sheets and the very latest industry and company information

There are many more features on the Auto4 website including many special offers and promotions so why not visit at www.auto4.co.uk

...at a click of a button!



Visit our website at: www.auto4.co.uk



- A TYRE REPAIR MATERIALS**
- B CHEMICAL PRODUCTS**
- C JANITORIAL, HEALTH AND SAFETY**
- D WHEEL BALANCE WEIGHTS**
- E AIR TOOLS AND ACCESSORIES**
- F AIR SERVICE AND ACCESSORIES**
- G GARAGE EQUIPMENT AND TOOLS**
- H VALVES AND VALVE HARDWARE**
- I 'O' RINGS AND BEAD SEATS**
- J CAPITAL EQUIPMENT**
- K PROTECTING YOUR EQUIPMENT**
- L INDEX - PRODUCT HEADINGS / DESCRIPTIONS**
- M INDEX - PRODUCT CODES**
- N TERMS AND CONDITIONS**
- O NOTES**
- P HOW TO ORDER**

PATCHES

Tech Europe are a leading manufacturer of tyre repair materials with products in the range endorsed by leading tyre manufacturers including Michelin, Goodyear, Bridgestone and Continental. Auto4 offer a wide range of Tech materials to cover all types of repair.

TECH TUBE PATCHES

PART NO.	DESCRIPTION	SIZE	QTY
150990	09 Tiny Round Tube Repair	A 25mm	140
150995	10 Mini Round Tube Repair	A 35mm	50
151000	11 Small Round Tube Repair	A 45mm	40
151002	11T Small Round Tube Repair Tub	B 45mm	160
151020	12 Medium Round Tube Repair	B 60mm	30
151022	12T Medium Round Tube Repair Tub	C 60mm	100
151040	13 Large Round Tube Repair	C 80mm	20
151042	13T Large Round Tube Repair Tub	C 80mm	75
151060	14 Maxi Round Tube Repair	D 100mm	20
151080	15 Giant Round Tube Repair	E 125mm	10
151088	16 Mini Oval Tube Repair	F 40 x 30mm	100
151090	17 Small Oval Tube Repair	F 65 x 40mm	30
151095	18 Medium Oval Tube Repair	F 100 x 50mm	20

TECH FUSION TUBE PATCHES (FOIL BACKED PATCHES)

PART NO.	DESCRIPTION	SIZE	QTY
151120	FT1 Fusion Round Tube Repair	G 34mm	100
151140	FT2 Fusion Round Tube Repair	G 43mm	50
151160	FT3 Fusion Round Tube Repair	G 50mm	50
151180	FT4 Fusion Round Tube Repair	G 80mm	40
151190	FT5 Fusion Round Tube Repair	G 90mm	10

TECH UNIVERSAL PATCHES

PART NO.	DESCRIPTION	SIZE	QTY
152000	115 Square All Purpose Repair	H 45 x 45mm	100
152020	116 Square All Purpose Repair	H 55 x 55mm	65
152040	111 Round All Purpose Repair	H 65mm	50

TECH FUSION UNIVERSAL PATCHES (FOIL BACKED PATCHES)

PART NO.	DESCRIPTION	SIZE	QTY
152100	FU3 Fusion All Purpose Repair	I 38 x 38mm	100
152120	FU4.5 Fusion All Purpose Repair	J 45 x 45mm	90
152140	FU6 Fusion All Purpose Repair	K 55 x 55mm	50
152160	FU8 Fusion All Purpose Repair	L 70 x 70mm	40
152180	FU10 Fusion All Purpose Repair	M 80 x 80mm	20

A



B



C



D



E



F



G



H



I



J



K



L



M



TECH RADIAL REPAIR UNITS

Produced with a soft gum for use on crown and shoulder injuries, use with Tech Vulcanising Cement (item code 101010), when used on large vehicles use after injury has been filled and cured.

PART NO.	DESCRIPTION	SIZE	QTY
153000	165 CT-10 Radial Repair	A 45 x 75mm	20
153010	164 CT-10HD Radial Repair	A 65 x 80mm	10
153014	166 CT-12HD Radial Repair	A 70 x 115mm	10
153020	167 CT-12 Radial Repair	A 60 x 110mm	10
153040	169 CT-14 Radial Repair	A 75 x 145mm	10
153060	170 CT-20 Radial Repair	A 75 x 125mm	10
153064	172 CT-22 Radial Repair	A 75 x 165mm	10
153070	174 CT-24 Radial Repair	A 75 x 215mm	10
153080	177 CT-33 Radial Repair	A 100 x 125mm	10
153100	178 CT-35 Radial Repair	A 125 x 150mm	10
153120	180 CT-40 Radial Repair	A 100 x 203mm	10
153140	182 CT-42 Radial Repair	A 125 x 250mm	5
153160	184 CT-44 Radial Repair	A 125 x 330mm	5
153170	186 CT-46 Radial Repair	A 140 x 405mm	5
153180	188 CT-50 Radial Repair	A 190 x 500mm	3
153200	196 CT-80 Radial Repair	A 150 x 195mm	5
153220	197 CT-82 Radial Repair	A 190 x 250mm	5
153240	198 CT-84 Radial Repair	A 215 x 290mm	5
153280	199 CT-86 Radial Repair	A 245 x 340mm	5



TECH FUSION RADIAL REPAIR UNITS (FOIL BACKED PATCHES)

PART NO.	DESCRIPTION	SIZE	QTY
154100	FR10HD Fusion Radial Repair	B 65 x 80mm	20
154120	FR12HD Fusion Radial Repair	B 70 x 115mm	10
154140	FR14 Fusion Radial Repair	B 75 x 145mm	10
154150	FR20 Fusion Radial Repair	B 75 x 125mm	10
154160	FR25 Fusion Radial Repair	B 100 x 125mm	10
154200	FR35 Fusion Radial Repair	B 125 x 170mm	10
154220	FR40 Fusion Radial Repair	B 100 x 200mm	10
154240	FR42 Fusion Radial Repair	B 125 x 250mm	5
154260	FR44 Fusion Radial Repair	B 125 x 330mm	5
154300	FR80 Fusion Radial Repair	B 150 x 195mm	5
154320	FR82 Fusion Radial Repair	B 190 x 250mm	5
154340	FR84 Fusion Radial Repair	B 215 x 290mm	5
154360	FR86 Fusion Radial Repair	B 245 x 340mm	5



TECH THERMACURE RADIAL REPAIR UNITS

Produced with soft black cushion gum provide excellent adhesion in all heat cure systems. Thermacure repairs are centre-over-injury designed and reinforced to restore the strength and flexibility to all radial tyres. Use with Black cement (item code 101040) in heat cure applications, or with Vulcanising (item code 101010) or Blue Cement (item code 101020) in cold cure applications.

PART NO.	DESCRIPTION	SIZE	QTY
153500	164R CT-10HDR Thermacure Radial Repair	C	10
153510	166R CT-12HDR Thermacure Radial Repair	C	10
153520	169R CT-14R Thermacure Radial Repair	C	10
153560	170R CT-20R Thermacure Radial Repair	C	10
153564	172R CT-22R Thermacure Radial Repair	C	10
153570	174R CT-24R Thermacure Radial Repair	C	10
153574	176R CT-26R Thermacure Radial Repair	C	10
153580	177R CT-33R Thermacure Radial Repair	C	10
153590	178R CT-35R Thermacure Radial Repair	C	10
153594	178R CT-35R Thermacure Radial Repair	C	5
153600	180R CT-40R Thermacure Radial Repair	C	10
153610	182R CT-42R Thermacure Radial Repair	C	5



TECH BIAS (CROSS PLY) REPAIR UNITS

Produced with soft grey cushion gum provide excellent adhesion when used with Vulcanising Cement (item code 101010). These patches are used to restore strength and flexibility of bias passenger, truck, tractor and OTR tyres.

PART NO.	DESCRIPTION	SIZE	QTY
154980	602 MP-2 Bias Repair	D 90 x 90mm	10
155000	603 BP-3 Bias Repair	D 100 x 100mm	10
155020	604 BP-4 Bias Repair	D 130 x 130mm	10
155040	605 BP-5 Bias Repair	D 165 x 165mm	10
155060	606 BP-6 Bias Repair	D 240 x 240mm	5
155080	607 BP-7 Bias Repair	D 290 x 290mm	5



TECH FUSION BIAS (CROSS PLY) REPAIR UNITS (FOIL BACKED PATCHES)

PART NO.	DESCRIPTION	SIZE	QTY
155120	FB3 Fusion Bias Repair	E 100 x 100mm	10
155140	FB4 Fusion Bias Repair	E 130 x 130mm	10
155160	FB5 Fusion Bias Repair	E 165 x 165mm	10



PLUGS AND INSERTS

Fill the injury with the appropriate stem or insert to seal out moisture and contaminants. All plugs and inserts are composed of a core of cured rubber covered with dual cure cushion gum or pre-cemented. The combination of compression and chemical vulcanisation forms a permanent bond to the casing.

PILOT WIRE PLUG PATCH

Use for crown puncture repairs in radial passenger and truck tyres. Combination patch and plug unit fills and seals the injury in one step. Pilot wire guides the stem into the injury for quick insertion. Dual cure cushion gum coats the stem and repair unit to create a permanent bond with the tyre.

PART NO.	DESCRIPTION	SIZE	QTY	
P05000	Plug Patch	A	3mm	60
P05020	Plug Patch	B	6mm	40
P05070	Plug Patch	D	10mm	10
P05100	Plug Patch Foil Back	C	6mm	40

TECH PLUG PATCHES

PART NO.	DESCRIPTION	SIZE	QTY	
021010	249 Uni-Seal Plug Repair	E	4.5mm	24
021020	250UL Uni-Seal Plug Repair	F	6mm	14
021022	250UL Uni-Seal Plug Repair	G	6mm	24
021040	251UL Uni-Seal Plug Repair	H	8mm	24
021060	291UL Uniseal Max Repair	I	10mm	10
021080	Radial-Seal Plug	J	15mm	10

TECH FUSION PLUG PATCHES

PART NO.	DESCRIPTION	SIZE	QTY	
021220	FPP Fusion Plug Patch Repair	K	4.5mm	24
021240	FPP Fusion Plug c/w Lead Wire	K	6mm	24

TECH PERMACURE REPAIRS

PART NO.	DESCRIPTION	SIZE	QTY	
157000	222 Permacure Repair	L	95mm	50
157002	220 Permacure Repair	M	95mm	50
157020	224 Permacure Repair Truck	N	130mm	40
157040	226 Permacure Repair Earthmover	O	190mm	25



THE WORLD LEADER IN TYRE REPAIR



TRUST TECH

- Over 75 years' industry experience
- ISO 9001:2008 certified
- Over 1 BILLION tyres repaired in more than 100 COUNTRIES using Tech products
- Customers include Michelin, Bridgestone, Continental and Goodyear
- All Tech tyre repair systems meet the requirements of industry standards including BS AU 159g and ECE 108/109
- Market leader in TPMS, offering over 90% coverage of direct TPMS enabled vehicles

PRODUCTS INCLUDE:

- Tube and All-Purpose Repairs
- Radial and Bias Repair Units
- Plug-Patch Combination Repairs
- Tyre Pressure Monitoring Systems (TPMS)
- RFID Tags
- Vulcanising Cements and Chemicals
- Tools and Wheel Service Products
- Nailhole Inserts and Repair Kits
- Valves and Valve Hardware



TECH FLOW SEAL INSERTS

Ideal for use in both bias and steel belted radial tyres. Unique grey cushion gum flows into the injury and completely seals the inner liner as well as broken cord and cable ends. The insert permanently vulcanises to the tyre and the tyre is immediately ready for use.

PART NO.	DESCRIPTION	SIZE	QTY
157050	204 Round Insert	A 50mm	40
157052	206 Oval Insert	B 50mm	40
157054	208 95mm Round Truck Insert	C 95mm	20
157056	209 Oval Truck Insert	95mm	20
157060	211 Round Insert	D 190mm	25
157080	212 Oval Insert	D 228mm	15
157100	217 Giant Oval Insert	E 210mm	10

BOW TIE INSERTS

Temporary nail hole repair for cross ply truck and earthmover tyres. For use with tyre plug needle (051020 and 051022).

PART NO.	DESCRIPTION	SIZE	QTY
051000	Earthmover Bow Tie	F 102 x 19mm	20
051001	Tech Earthmover Bow Tie	G 100 x 22mm	20

STRING SYSTEMS

Rubber-coated strings designed for the temporary repair of tread punctures. For use with tyre repair string needle (051140 and 051150).

PART NO.	DESCRIPTION	SIZE	QTY
051060	Black String Tyre Repair	H (12") 300mm	40
051070	Black Chemicure Tyre Repair	I (14") 350mm	40
051110	Brown Tyre Repair String	J (4") 100mm	50
051120	Brown Tyre Repair String	K (8") 200mm	30

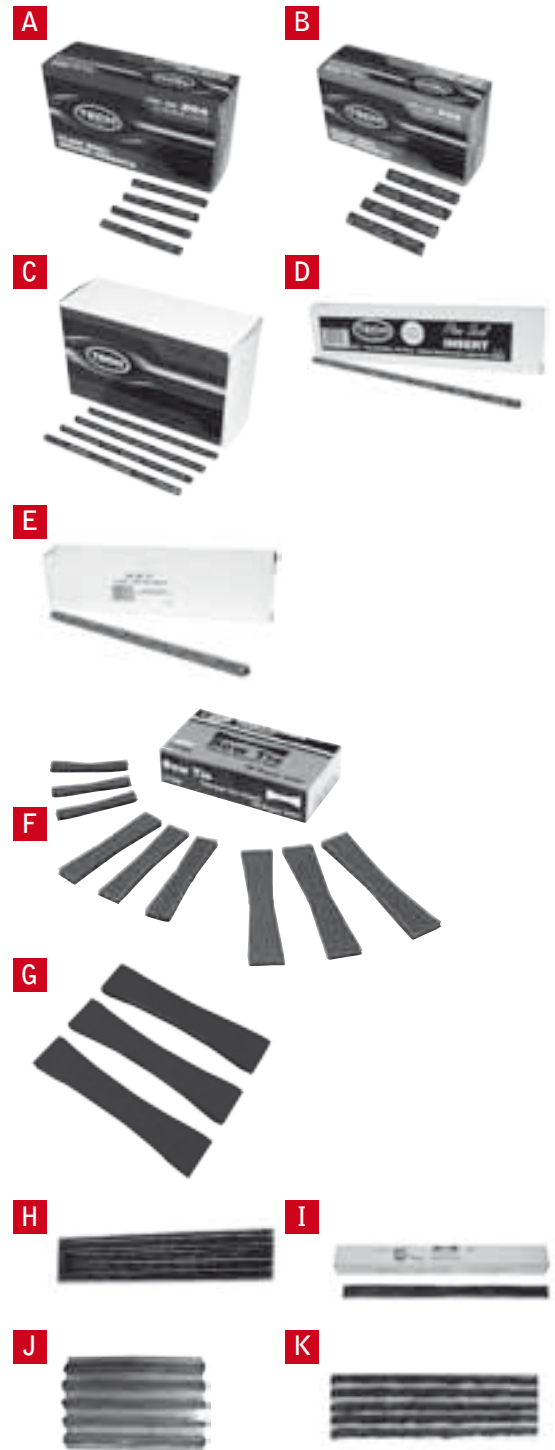

**Why not visit
our website at
auto4.co.uk**

TYRE INJURY FILLER

Cold curing rubber compound used for filling minor tread penetration.
For use with tyre injury filler gun (015120).

PART NO.	DESCRIPTION	SIZE	QTY
015120	Tyre Injury Filler Gun (Cartridges not included)	A	1
015124	Twin Cartridge Application Gun	B	50ml
015141	Tyre Injury Filler Cartridge	C	1
015142	Black Silicone Sealant - Tyre Dough Alternative	D	310ml
015144	Black Polyurethane Twin Cartridge Adhesive	E	50ml
015154	Mixer Nozzles	F	10
000320	Vulcanising Compound A & B	FF	1



CHEMICALS

CEMENTS

- Chemical vulcanising cement contains no CFC's and is less toxic
- Fast drying and cures tube and tyre repairs with or without heat

PART NO.	DESCRIPTION	SIZE	QTY
101010	Cement Fast Dry Premium	G	237ml
101012	761 Chemical Vulcanising Fluid	H	0.95l
101020	Heavy Duty Blue Cement	I	225ml
101024	776 HD Blue Vulcanising Cement	J	945ml
051080	770 Flow Seal Squeeze Bottle	K	205ml

TECH BLACK CEMENT

PART NO.	DESCRIPTION	SIZE	QTY
101040	1082 Tem Vulc Black Cement	L	0.95l

BEAD SEALER

- Bead sealer seals leaks between bead and wheel rim
- Non-flammable

PART NO.	DESCRIPTION	SIZE	QTY
202500	Bead Sealer	M	945ml

INNER LINER SEALER

PART NO.	DESCRIPTION	SIZE	QTY
202521	738 Security Coat	N	470ml

BEAD LUBRICANTS

Auto4 mounting pastes, liquids, creams and waxes have been specifically developed and tested respecting their specific fields of application, mounting conditions, tools, tyre changing equipment, tyre-wheel combinations and the environment.

PART NO.	DESCRIPTION		SIZE	QTY
201000	Tyre Mounting Paste	A	5kg	1
201010	Tyre Mounting Paste Black	A	5kg	1
201020	Tyre Mounting Cream	B	5kg	1
201040	Tyre Mounting Wax	C	5kg	1
201060	Tyre Mounting Aeropaste	D	5kg	1
201080	Tyre Mounting Aerowax	E	5kg	1
201110	Tyre Bead Lubricant	F	5ltr	1
201130	Tyre Bead Lubricant	G	25ltr	1
201140	Tyre & Tube Mounting Compound	H	5ltr	1
201160	Tyre & Tube Mounting Compound	H	10kg	1
201190	Rim Ease	I	3.8ltr	1
201195	Rim Ease	J	5gallon	1
201200	BIBUP Tyre Lubricant Aerosol	K	400ml	1
901020	E/M Bead Grease Medium*	L	5kg	1
901030	Tigre Grease*	M	4kg	1
901034	Tigre 90 Grease	N	5kg	1
901060	E/M Bead Grease Medium*	O	12kg	1
901080	E/M Bead Grease Medium*	P	185kg/205ltr	1

* For handling, mounting and dismantling tyres for trucks, earthmovers and farm vehicles.



SEALANTS, ADHESIVES, LEAK FINDER AND DUSTING CHALK

PART NO.	DESCRIPTION		SIZE	QTY
201180	Rimseal Soft*	A	5kg	1
201182	Rimseal Hard*	B	5kg	1
201187	Black Rimseal*	B	5kg	1
202540	OKO Tyre Sealant**	C	1.25ltr	1
202570	OKO Tyre Sealant***	D	25ltr	1
202580	OKO Tyre Sealant Pump	E		1
202700	Exhaust Paste Cartridge	F	500g	1
202750	Epoxy Putty Steel Stick	G	180g	1
203140	French Chalk Shaker	H	400g	1

* Designed for corrosion protection, revolutionary system to avoid leaks. Suitable for steel and alloy wheels. Will seal porous aluminium wheels.

** Designed to seal punctures instantly with a permanent and strong air tight seal. For off road vehicles only.

*** For use with Pump (202580).



Tyre Sealant also available for motorbike and car.

SEALANTS, ADHESIVES, LEAK FINDER AND DUSTING CHALK (CONTINUED)

PART NO.	DESCRIPTION	SIZE	QTY
203160	French Chalk	5kg	1
204000	Leak Seek Concentrate	I 1ltr	1
204010	Leak Seek Concentrate	I 500ml	1
FG60512	Loctite 243 Thread Locker	J 10ml	1
FK94670	Caulking Gun Heavy Duty	K	1
FX60280	Super Glue Bottle	L 5g	5
FX60300	Super Glue Bottles	M 20g	3
FX60330	Lock and Seal Adhesive	N 50ml	1
FX60340	Stud and Bearing Adhesive	O 50ml	1
FX60370	Brake/Air Sealant Adhesive	P 65ml	1
FX60400	Silicone Sealant Clear	Q 310ml	3
FX60402	Silicone Sealant Clear	Q 310ml	12
FX60450	5 Minute Epoxy Resin Adhesive	R 25g	1
FX61600	Spray Adhesive	S 400ml	6



OILS, LUBRICANTS AND CLEANERS

PART NO.	DESCRIPTION	SIZE	QTY
202000	Penetrating Oil Aerosol 400ml	A 400ml	1
202020	Air Tool Oil	B 1ltr	1
202030	Myers Air Tool Conditioner	C 360ml	1
202040	Hydraulic Jack Oil	D 1ltr	1
202044	Hydraulic Oil ISO46	E 1ltr	1
202060	SAE 46 Compressor Oil	F 1ltr	1
202100	Wheel Degreaser	G 5ltr	1
202110	Tyre Cleaner	H 5ltr	1
202114	Tyre Foam Aerosol	I 650ml	1
202120	Copper Grease	J 500g	1
202140	Copper Grease Aerosol	K 400ml	1
202160	White Grease Aerosol With PTFE	L 400ml	1
202165	Silicone Grease Aerosol	M 400ml	1
202170	Lithium Service Grease	N 400ml	1
202172	Lithium Grease	O 500g	1
202174	Petroleum Jelly	P 500g	1
202176	Ceramic Grease	Q 500g	1
202180	Penetrating Oil	R 5ltr	1
202220	WD40 Penetrating Oil	S 5ltr	1
202262	GT85 Professional Maintenance Aerosol	T 400ml	1
202270	Silicone Spray Aerosol	U 400ml	1

OILS, LUBRICANTS AND CLEANERS (CONTINUED)

PART NO.	DESCRIPTION	SIZE	QTY
202300	Brake Cleaner Aerosol c/w CO2 Propellant	V	500ml 1
202406	Transmission Fluid ATF Dexron II	W	1ltr 1
202410	Transmission Fluid ATF Dexron III	X	1ltr 1
202421	Carb/Fuel Injector Cleaner Aerosol	Y	400ml 1
202430	Injector Cleaner Petrol	Z	265ml 1
202440	Injector Cleaner Diesel	A	265ml 1
202452	Radiator Flush	B	325ml 1
202470	Silicone/Gasket Sealant HT Black	C	200ml 1
202472	Hylomar Universal Blue	D	40g 1
202474	K-Seal Permanent Coolant Leak Repair	E	236ml 1
FG65400	4-Jaw Hydraulic Grease Gun Connector	F	5
FG65510	Flexi Grease Gun Hose 1/8" BSP Male 12"	G	3
FG65520	Flexi Grease Gun Hose 1/8" BSP Male 18"	H	3
FG65700	Heavy Duty Lever Grease Gun	I	1
FX61250	Power Spray	J	400ml 12
FX61270	Power Spray	K	5ltr 1
FX61425	Brake Cleaner	L	2.5ltr 2
FX61500	Electrical Cleaner	M	400ml 6
FX61550	Battery Terminal Protector	N	400ml 6
FX61650	Cockpit Shine	O	400ml 6
FX61740	Chain Lube Spray	P	400ml 6
FX61780	Clear Grease	Q	400ml 6

V



W



X



Y



Z



A



B



C



D



E



F



G



H



I



J



K



L



M



N



O



P



Q



follow us on

twitter

@Auto4Ltd



ProTect Orange HD gloves are silicone-free nitrile gloves, suitable for use in the processes which are sensitive to the presence of silicones. With raised diamond nodules to create a larger surface area, these gloves have high grip and allow liquids to be channelled away during use.

ProTect Latex are heavy weight, extended cuff powder-free, durable and tough single use gloves.



Designed specifically for automotive and chemical use, Commercial Black Nitrile gloves are chemical and tear resistant offering good resistance to solvents, oil grease and hydrocarbons.

Commercial Latex provides great comfort and dexterity and the optimal barrier protection against inorganic chemicals.

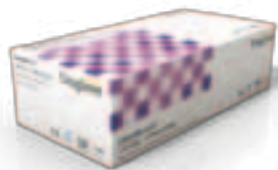

Unicare Soft Nitrile gloves are a unique blend of nitrile and vinyl which offers superior stretch and fit to standard vinyl gloves.

Unicare Soft Stretch Vinyl gloves are a cost-effective alternative to latex and nitrile gloves, while protecting against cross contamination, dirt and potential irritants in low-risk situations.



Black Pearl gloves are powder-free tear resistant specially chlorinated to offer exceptional tactile sensitivity and comfort.

Unicare Soft Nitrile gloves are powder-free, chemical and tear resistant single use gloves that offer better puncture and abrasion resistance than latex and vinyl, while feeling comfortable and flexible on the hands.



PRE-BUFF CLEANERS

A solvent used to remove silicons, dusting chalk and other agents from the inside of the tyre prior to mechanical buffing.

PART NO.	DESCRIPTION	SIZE	QTY
102000	Pre-Buff Cleaner	A	1ltr
102020	Pre-Buff Cleaner	B	5ltr
102040	Pre-Buff Cleaner Aerosol	C	400ml
102044	TECH 704-AE2 Aerosol Rub-O-Matic	D	438ml



PERSONAL PROTECTIVE EQUIPMENT

PART NO.	DESCRIPTION	SIZE	QTY
244242	Re-useable Nylon Seat Covers Blue		1
244250	Safety Spectacles	Q	1
244260	Safety Goggles	R	1
244270	Ear Defenders	S	1
244340	HSE 1 Person Travel First Aid Kit	T	1
244640	Safety Cones 2 Piece	U	500mm
244700	Dry Powder Fire Extinguisher	V	2kg
244243	Bump Cap	W	1
244248	Face Mask Disposable	X	5
244344	Eye Wash Pods	Y	20ml
244271	High Visibility Vest Yellow	Z	L
244272	High Visibility Vest Yellow	Z	XL
244274	High Visibility Vest Long Sleeve Yellow	ZZ	L
244275	High Visibility Vest Long Sleeve Yellow	ZZ	XL



Why not visit
our website at
auto4.co.uk

GLOVES

PART NO.	DESCRIPTION	SIZE	QTY
012620	Impact Gel Palm Mechanic's Gloves	A Medium	Pair
012640	Impact Gel Palm Mechanic's Gloves	A Large	Pair
012660	Impact Gel Palm Mechanic's Gloves	A Extra Large	Pair
015010	Leather Rigger Gloves	B	Pair
015012	Nitrile Coated Knitted Glove	C Large	Pair
015014	PVC Gloves	D	Pair
015018	Tuff Grip Professional Gloves	E Large	Pair
244782	Black Nitrile Powder Free Gloves	F Medium	100
244784	Black Nitrile Powder Free Gloves	F Large	100
244786	Black Nitrile Powder Free Gloves	F Extra Large	100
244840	Blue Nitrile Powder Free Gloves	G Medium	100
244860	Blue Nitrile Powder Free Gloves	G Large	100
244880	Blue Nitrile Powder Free Gloves	G Extra Large	100
244962	Uni-Trile Gloves Blue Powder Free Vitriile	H Medium	100
244964	Uni-Trile Gloves Blue Powder Free Vitriile	H Large	100
244966	Uni-Trile Gloves Blue Powder Free Vitriile	H Extra Large	100



HAND CARE

PART NO.	DESCRIPTION	SIZE	QTY
003000	Gojo Wall Dispenser	A	1
003020	Gojo Hand Cleaner	B 2ltr	1
003040	Hand Cleansing Gel	C 5ltr	1
Z01744	Industrial Hand Wipes	D	150



CLEANING

PART NO.	DESCRIPTION	SIZE	QTY
244219	Dispenser for Centrefeed Blue Roll	E	1
244220	Centrefeed Blue Roll	F 190mm x 150m	6
244222	Centrefeed Blue Roll PREMIUM	190mm x 150m	6
244232	Recycled White Floor Mats (Flat Pack)	G	100
244234	Recycled White Floor Mats (Roll)	H	400
244238	Seat Cover Dispenser - Single Bar	I	1
244240	Recycled Polythene Disposable Seat Covers	J	100
244241	Water Resistant Van Seat Protectors	RR	2
Z01280	Firm Broom Head	K 12"/305mm	1
Z01300	Firm Broom Head	K 24"/610mm	1



■ CLEANING (CONTINUED)

PART NO.	DESCRIPTION	SIZE	QTY
Z01310	Soft Broom Head	L 24"/610mm	1
Z01320	Broom Handle	M 48"/1219mm	1
Z01322	Broom Handle	M 60"/1524mm	1
Z01340	Galvanised Mop Bucket	N	1
Z01350	Plastic Mop Bucket	O	1
Z01360	Mop Head	P	1
Z01370	Mop Handle	Q 48"/1219mm	1
Z01380	Toilet Brush Set	R	1
Z01390	Nail Brush	S	2
Z01520	Floor Cleaning Gel	T	1
Z01522	Washing Up Liquid	U 5ltr	1
Z01523	Cream Cleaner	V 500ml	1
Z01524	Glass Cleaner	W 500ml	1
Z01525	Toilet Soap Bar	X	5
Z01526	Furniture Polish Aerosol	Y 300ml	1
Z01528	Air Freshener	Z 400ml	1
Z01529	Toilet Block Clip On	AA	6
Z01530	Channel Cube/Toilet Blocks Citrus Zest	BB 3kg	1
Z01540	Multi-Clean	CC 5ltr	1
Z01560	Toilet Cleaner	DD 750ml	1
Z01570	Bleach	EE 5ltr	1
Z01730	Toilet Rolls 2 Ply 200 Sheet	FF	36
Z01732	Scourer Sponge	GG	10
Z01734	Dishcloths (Blue Edge) Medium White	HH 16 x 12"	10
Z01736	J-Type Blue Disposable Cloth	II	100
Z01737	Dusters Medium	JJ 14 x 20"	10
Z01750	General Purpose Rags	KK 10kg	2
Z01760	Swing Bin	LL 50ltr	
Z01762	Dustbin Black Plastic c/w Lid	MM 80ltr	
Z01780	Swing Bin Liners	NN	100
Z01820	Short Handle Shovel	OO 7" Wide	
Z01840	Dust Pan & Brush Set	PP	
Z01860	Oil Absorbent Granules - New Safety Tread	QQ 30ltr	



CAR WEIGHTS

WEGMANN AFTERMARKET WEIGHTS

The F range is designed and engineered by Hofmann in Germany. This premium brand wheel balance weight has been specifically manufactured for the aftermarket to fit the maximum number of rims.

The weights are precisely made from high quality zinc to ensure weight consistency and maintain a good appearance. The clip has been designed to minimise movement on the rim.
(Manufactured to EU legislation 2000/53/Ec).

WEGMANN POWER WEIGHTS

The Hofmann power weight is aimed specifically at original equipment manufacturers or tyre depots where only the very best balance weight will do.

Manufactured from the highest quality zinc all weights are plated and coated to offer the optimum corrosion protection whilst offering a high quality finish from an established and renowned design. The clip is designed to minimise movement on the rim.

This weight is used by many of the major car manufacturers including Ford, Toyota, BMW, Volkswagen, Mercedes amongst many others.

BALANCE WEIGHTS FOR STEEL RIMS

WEGMANN POWER WEIGHTS

PART NO.	DESCRIPTION	SIZE	QTY
T03000	Hofmann Power Zinc Weight For Steel Wheels - Coated	A 5g	100
T03020	Hofmann Power Zinc Weight For Steel Wheels - Coated	A 10g	100
T03040	Hofmann Power Zinc Weight For Steel Wheels - Coated	A 15g	100
T03060	Hofmann Power Zinc Weight For Steel Wheels - Coated	A 20g	100
T03080	Hofmann Power Zinc Weight For Steel Wheels - Coated	A 25g	100
T03100	Hofmann Power Zinc Weight For Steel Wheels - Coated	A 30g	100
T03120	Hofmann Power Zinc Weight For Steel Wheels - Coated	A 35g	50
T03140	Hofmann Power Zinc Weight For Steel Wheels - Coated	A 40g	50
T03160	Hofmann Power Zinc Weight For Steel Wheels - Coated	A 45g	50
T03180	Hofmann Power Zinc Weight For Steel Wheels - Coated	A 50g	50
T03200	Hofmann Power Zinc Weight For Steel Wheels - Coated	A 55g	50
T03220	Hofmann Power Zinc Weight For Steel Wheels - Coated	A 60g	50

A



■ WEGMANN AFTERMARKET WEIGHTS UNCOATED

PART NO.	DESCRIPTION	SIZE	QTY
S01000	Premium Zinc Weight For Steel Wheels	B 5g	100
S01020	Premium Zinc Weight For Steel Wheels	B 10g	100
S01040	Premium Zinc Weight For Steel Wheels	B 15g	100
S01060	Premium Zinc Weight For Steel Wheels	B 20g	100
S01080	Premium Zinc Weight For Steel Wheels	B 25g	100
S01100	Premium Zinc Weight For Steel Wheels	B 30g	100
S01120	Premium Zinc Weight For Steel Wheels	B 35g	50
S01140	Premium Zinc Weight For Steel Wheels	B 40g	50
S01160	Premium Zinc Weight For Steel Wheels	B 45g	50
S01180	Premium Zinc Weight For Steel Wheels	B 50g	50

B



■ STANDARD AFTERMARKET WEIGHTS

PART NO.	DESCRIPTION	SIZE	QTY
T04000	Standard Steel Weight For Steel Wheels - Coated	C 5g	100
T04020	Standard Steel Weight For Steel Wheels - Coated	C 10g	100
T04040	Standard Steel Weight For Steel Wheels - Coated	C 15g	100
T04060	Standard Steel Weight For Steel Wheels - Coated	C 20g	100
T04080	Standard Steel Weight For Steel Wheels - Coated	C 25g	100
T04100	Standard Steel Weight For Steel Wheels - Coated	C 30g	100
T04120	Standard Steel Weight For Steel Wheels - Coated	C 35g	50
T04140	Standard Steel Weight For Steel Wheels - Coated	C 40g	50
T04160	Standard Steel Weight For Steel Wheels - Coated	C 45g	50
T04180	Standard Steel Weight For Steel Wheels - Coated	C 50g	50

C



BALANCE WEIGHTS FOR ALLOY RIMS

■ WEGMANN POWER WEIGHTS

PART NO.	DESCRIPTION	SIZE	QTY
V03000	Hofmann Power Zinc Weight For Alloy Wheels - Coated	A 5g	100
V03020	Hofmann Power Zinc Weight For Alloy Wheels - Coated	A 10g	100

A



■ WEGMANN POWER WEIGHTS (CONTINUED)

PART NO.	DESCRIPTION	SIZE	QTY
V03040	Hofmann Power Zinc Weight For Alloy Wheels - Coated	A 15g	100
V03060	Hofmann Power Zinc Weight For Alloy Wheels - Coated	A 20g	100
V03080	Hofmann Power Zinc Weight For Alloy Wheels - Coated	A 25g	100
V03100	Hofmann Power Zinc Weight For Alloy Wheels - Coated	A 30g	100
V03120	Hofmann Power Zinc Weight For Alloy Wheels - Coated	A 35g	50
V03140	Hofmann Power Zinc Weight For Alloy Wheels - Coated	A 40g	50
V03160	Hofmann Power Zinc Weight For Alloy Wheels - Coated	A 45g	50
V03180	Hofmann Power Zinc Weight For Alloy Wheels - Coated	A 50g	50
V03200	Hofmann Power Zinc Weight For Alloy Wheels - Coated	A 55g	50
V03220	Hofmann Power Zinc Weight For Alloy Wheels - Coated	A 60g	50



■ WEGMANN AFTERMARKET WEIGHTS UNCOATED

PART NO.	DESCRIPTION	SIZE	QTY
U01000	Premium Zinc Weight For Alloy Wheels	B 5g	100
U01020	Premium Zinc Weight For Alloy Wheels	B 10g	100
U01040	Premium Zinc Weight For Alloy Wheels	B 15g	100
U01060	Premium Zinc Weight For Alloy Wheels	B 20g	100
U01080	Premium Zinc Weight For Alloy Wheels	B 25g	100
U01100	Premium Zinc Weight For Alloy Wheels	B 30g	100
U01120	Premium Zinc Weight For Alloy Wheels	B 35g	50
U01140	Premium Zinc Weight For Alloy Wheels	B 40g	50
U01160	Premium Zinc Weight For Alloy Wheels	B 45g	50
U01180	Premium Zinc Weight For Alloy Wheels	B 50g	50



follow us on
twitter
@Auto4Ltd

Quality sign for
tyre professionals



S1000 Evoluzione



A92



S560



S76EC Touch



PSR50

■ WEGMANN AFTERMARKET WEIGHTS COATED

PART NO.	DESCRIPTION		SIZE	QTY
V01000	Premium Zinc Weight For Alloy Wheels - Coated	C	5g	100
V01020	Premium Zinc Weight For Alloy Wheels - Coated	C	10g	100
V01040	Premium Zinc Weight For Alloy Wheels - Coated	C	15g	100
V01060	Premium Zinc Weight For Alloy Wheels - Coated	C	20g	100
V01080	Premium Zinc Weight For Alloy Wheels - Coated	C	25g	100
V01100	Premium Zinc Weight For Alloy Wheels - Coated	C	30g	100
V01120	Premium Zinc Weight For Alloy Wheels - Coated	C	35g	50
V01140	Premium Zinc Weight For Alloy Wheels - Coated	C	40g	50
V01160	Premium Zinc Weight For Alloy Wheels - Coated	C	45g	50
V01180	Premium Zinc Weight For Alloy Wheels - Coated	C	50g	50
V01300	Premium Zinc Weights For Alloy Wheels - Coated		Assorted	100



■ STANDARD AFTERMARKET WEIGHTS

PART NO.	DESCRIPTION		SIZE	QTY
V04000	Standard Steel Weight For Alloy Wheels - Coated	E	5g	100
V04020	Standard Steel Weight For Alloy Wheels - Coated	E	10g	100
V04040	Standard Steel Weight For Alloy Wheels - Coated	E	15g	100
V04060	Standard Steel Weight For Alloy Wheels - Coated	E	20g	100
V04080	Standard Steel Weight For Alloy Wheels - Coated	E	25g	100
V04100	Standard Steel Weight For Alloy Wheels - Coated	E	30g	100
V04120	Standard Steel Weight For Alloy Wheels - Coated	E	35g	50
V04140	Standard Steel Weight For Alloy Wheels - Coated	E	40g	50
V04160	Standard Zinc Weight For Alloy Wheels - Coated	E	45g	50
V04180	Standard Steel Weight For Alloy Wheels - Coated	E	50g	50



SPECIALIST BALANCE WEIGHTS

■ JAPANESE ALLOY BALANCE WEIGHT

This weight has a higher sitting clip and will fit thicker section wheels which may be found on some Japanese cars including Nissan, Toyota and Honda.

The weight will typically fit rims with a height of 6.6/7.5mm.

PART NO.	DESCRIPTION	SIZE	QTY
W01000	Premium Zinc Weight For Japanese Wheels - Coated	A	5g 100
W01020	Premium Zinc Weight For Japanese Wheels - Coated	A	10g 100
W01040	Premium Zinc Weight For Japanese Wheels - Coated	A	15g 100
W01060	Premium Zinc Weight For Japanese Wheels - Coated	A	20g 100
W01080	Premium Zinc Weight For Japanese Wheels - Coated	A	25g 100
W01100	Premium Zinc Weight For Japanese Wheels - Coated	A	30g 100
W01120	Premium Zinc Weight For Japanese Wheels - Coated	A	35g 50
W01140	Premium Zinc Weight For Japanese Wheels - Coated	A	40g 50
W01160	Premium Zinc Weight For Japanese Wheels - Coated	A	45g 50
W01180	Premium Zinc Weight For Japanese Wheels - Coated	A	50g 50
W01260	Assorted Premium Zinc Weight Japanese Wheels - Coated		100

A



■ HOFMANN BALANCE WEIGHT TYPE 260

PART NO.	DESCRIPTION	SIZE	QTY
W02000	260 BMW/AUDI/VW 2 Pce Weight Coated Clips extra	B	5g 100
W02020	260 BMW/AUDI/VW 2 Pce Weight Coated Clips Extra	B	10g 100
W02040	260 BMW/AUDI/VW 2 Pce Weight Coated Clips Extra	B	15g 100
W02060	260 BMW/AUDI/VW 2 Pce Weight Coated Clips Extra Item	B	20g 100
W02080	260 BMW/AUDI/VW 2 Piece Weight - Coated Clips Extra	B	25g 100
W02100	260 BMW/AUDI/VW 2 Piece Weight - Coated Clips Extra	B	30g 100

B



■ HOFMANN BALANCE WEIGHT TYPE 260 (CONTINUED)

PART NO.	DESCRIPTION	SIZE	QTY
W02120	260 BMW/AUDI/VW 2 Piece Weight - Coated Clips Extra	B	35g 50
W02140	260 BMW/AUDI/VW 2 Piece Weight - Coated Clips Extra	B	40g 50
W02160	260 BMW/AUDI/VW 2 Piece Weight - Coated	B	45g 50
W02180	260 BMW/AUDI/VW 2 Piece Weight - Coated	B	50g 50
W02200	260 BMW/AUDI/VW 2 Piece Weight - Coated	B	55g 50
W02220	260 BMW/AUDI/VW 2 Piece Weight - Coated	B	60g 50
W02300	Assorted VAG 2 Piece Lead Free Weights - Coated		100



■ HOFMANN BALANCE WEIGHT TYPE 261 AND 280A

PART NO.	DESCRIPTION	SIZE	QTY
W03000	Daimler/Chrysler 2 Piece Lead Free Coated Weight	A	5g 100
W03020	Daimler/Chrysler 2 Piece Lead Free Coated Weight	A	10g 100
W03040	Daimler/Chrysler 2 Piece Lead Free Coated Weight	A	15g 100
W03060	Daimler/Chrysler 2 Piece Lead Free Coated Weight	A	20g 100
W03080	Daimler/Chrysler 2 Piece Lead Free Coated Weight	A	25g 100
W03100	Daimler/Chrysler 2 Piece Lead Free Coated Weight	A	30g 100
W03120	Daimler/Chrysler 2 Piece Lead Free Coated Weight	A	35g 50
W03140	Daimler/Chrysler 2 Piece Lead Free Coated Weight	A	40g 50
W03160	Daimler/Chrysler 2 Piece Lead Free Coated Weight	A	45g 50
W03180	Daimler/Chrysler 2 Piece Lead Free Coated Weight	A	50g 50
W03300	Ass'd Daimler/Chrysler 2 Piece Lead Free Weight - Coate	A	100
W04300	Assorted 280A VW Lead Free Weights - Coated		100



ADHESIVE WEIGHTS

CAR AND MOTORCYCLE

PART NO.	DESCRIPTION	SIZE	QTY
X00500	Motorcycle Adhesive Weights	B 6x5g x 6x2.5g	50
X01100	Steel Standard Adhesive Weights	C 10 x 5g	100
X01120	Steel Premium Adhesive Weights	D 10 x 5g	50
X01130	Steel Premium Adhesive WeightsCoated	D 10 x 5g	50
X01135	Steel Premium Adhesive WeightsCoated Black	E 10 x 5g	50
X00706	Motorcycle Adhesive Weights Uncoated	F 8 x 5g	50
X00710	Motorcycle Adhesive Weights Black	G 8 x 5g	50
X01076	303-2 Lead Adhesive Weights 60g Strip Coated	H 5 x 10g	100
X01113	Steel Premium Adhesive Weight Fingerlift Unbranded	D 10 x 5g	100

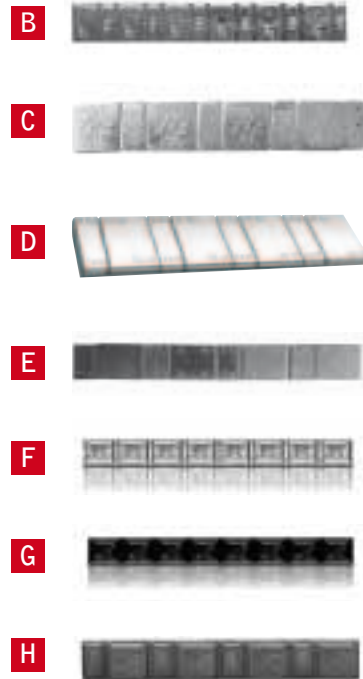

INDIVIDUAL ADHESIVE WEIGHTS TYPE 360

This weight is made of a fine zinc alloy. The weights have a height of 5.8mm (incl.tape) and a width of 15mm. All weights are provided with a silver synthetic coating, which complies with the current vehicle standard specified for externally applied parts.

PART NO.	DESCRIPTION	SIZE	QTY
X02000	Individual Zinc Adhesive Weight Coated	A 5g	100
X02020	Individual Zinc Adhesive Weight Coated	A 10g	100
X02040	Individual Zinc Adhesive Weight Coated	A 15g	100
X02060	Individual Zinc Adhesive Weight Coated	A 20g	100
X02080	Individual Zinc Adhesive Weight Coated	A 25g	100
X02100	Individual Zinc Adhesive Weight Coated	A 30g	100
X02120	Individual Zinc Adhesive Weight Coated	A 35g	50
X02140	Individual Zinc Adhesive Weight Coated	A 40g	50
X02160	Individual Zinc Adhesive Weight Coated	A 45g	50
X02180	Individual Zinc Adhesive Weight Coated	A 50g	50
X02200	Individual Zinc Adhesive Weight Coated	A 55g	50
X02220	Individual Zinc Adhesive Weight Coated	A 60g	50
X02300	Assorted Individual Zinc Adhesive Weights Coated		100



TRUCK WEIGHTS

TRUCK TUBELESS WEIGHTS TYPE 530 (TUBELESS RIMS)

PART NO.	DESCRIPTION	SIZE	QTY
H01000	Tubeless Truck	B	50g 10
H01020	Tubeless Truck	B	100g 10
H01040	Tubeless Truck	B	150g 10
H01060	Tubeless Truck	B	200g 10
H01080	Tubeless Truck	B	300g 10
H01100	Tubeless Truck	B	400g 10
H01120	Tubeless Truck	B	500g 10
H01500	Mixed Truck Weights		50



TRUCK WEIGHTS TYPE 555 (ALCOA TRUCK RIMS)

PART NO.	DESCRIPTION	SIZE	QTY
I01020	555 Truck Alloy	C	75g 10
I01040	555 Truck Alloy	C	100g 10
I01060	555 Truck Alloy	C	125g 10



TRUCK WEIGHTS TYPE 556 (ALCOA TRUCK RIMS)

PART NO.	DESCRIPTION	SIZE	QTY
I01120	556 Truck Alloy	C	75g 10
I01140	556 Truck Alloy	C	100g 10
I01160	556 Truck Alloy	C	125g 10

TRUCK ADHESIVE WEIGHTS

PART NO.	DESCRIPTION	SIZE	QTY
X01200	Truck Adhesive Weights	5x20g	10
X01220	Truck Adhesive Weights	4x50g	10

WHEEL BALANCING POWDER

PART NO.	DESCRIPTION	SIZE	QTY
H02000	Easi-Balance Powder	F	100g 1
H02020	Easi-Balance Powder	F	300g 1
H02040	Easi-Balance Powder	F	350g 1
H03000	Easi-Balance Powder	G	7.5kg 1



**UNIVERSAL AIR TOOLS IS
RECOGNISED AS THE UK'S LEADING
PNEUMATIC SPECIALIST SUPPLIER
OF HIGH QUALITY AIR TOOLS TO
THE GARAGE, TYRE, BODYSHOP &
INDUSTRIAL MARKETS FOR OVER 43
YEARS.**



Universal Air Tools

**PROUDLY
SPONSORS
ARDEN**



AIRCAT **PNEUMATIC TOOLS**®

A DIVISION OF UNIVERSAL AIR TOOL COMPANY

AIR TOOLS

We have a range of tools from CP and UAT to suit every pocket and application.

■ IMPACT WRENCH 1/2" DRIVE

PART NO.	DESCRIPTION	SIZE	QTY	
012001	1/2" Dr. Impact Wrench UT8138	A	1/2"	1
012004	1/2" Dr. Impact Wrench CP734	B	1/2"	1
012010	1/2" Dr. Impact Wrench CP749H	C	1/2"	1
012011	1/2" Dr. Impact Wrench AC1450	D	1/2"	1

- 012001, Power 780ft lbs, Weight 2.1kg
- 012004, Power 425ft lbs, Weight 2.3kg
- 012010, Power 625ft lbs, Weight 2.49kg
- 012011, Power 800ft lbs, Weight 2.63kg

■ IMPACT WRENCH 1" DRIVE

PART NO.	DESCRIPTION	SIZE	QTY	
012072	1" Dr. Impact Wrench UT8419	E	1"	1
012091	1" Dr. Impact Wrench CP7782-6	F	1"	1
012092	1" Dr. Impact Wrench AC1900A	G	1"	1
012093	1" Dr. Impact Wrench UT8468	H	1"	1

- 012072, Power 1600ft lbs, Weight 12kg
- 012091, Power 2150ft lbs, Weight 11.6kg
- 012092, Power 1900ft lbs, Weight 12.97kg
- 012093, Power 1800ft lbs, Weight 7.5kg

■ IMPACT WRENCH 3/4" DRIVE

PART NO.	DESCRIPTION	SIZE	QTY	
012103	3/4" Dr. Impact Wrench AC1777	I	3/4"	1

■ AIR BUFFING TOOLS

- Adjustable power regulator for precise control
- Lock off throttle to prevent accidental start up
- Excellent for tyre scuffing, cleaning tyre mouldings and general high speed polishing and grinding

PART NO.	DESCRIPTION	SIZE	QTY	
218000	Air Buffing Tool Collet Max RPM 22000	J	6mm	1
218030	Air Buffing Tool Collet CP872 Max RPM 22000	K	1/4"	1
218034	Air Buffing Tool Collet UT5721 Max RPM 20000	L	1/4"	1
218042	Air Buffing Tool AC6403 Max RPM 3600	M		1



Chicago Pneumatic for all your tooling needs.



Chicago Pneumatic tools are reliable, ergonomic, robust and easy to use!

ULTRA Compact Impacts: Designed to reach the bolts other tools can't!



CP7732 1/2" Stubby Metal Impact

ULTRA COMPACT:
Length only 112mm

POWERFUL:
610 Nm (REV)

LIGHTWEIGHT:
Only 1.3 kgs

DURABLE:
Jumbo Hammer



CP7762 3/4" REAL Stubby Impact

ULTRA COMPACT:
Length only 158.7mm

POWERFUL:
1,420 Nm (REV)

LIGHTWEIGHT:
Only 3.0 kgs

HIGH DURABILITY:
Twin hammer
mechanism

People.
Passion.
Performance.



Chicago
Pneumatic

AIR DRILLS, RATCHETS, HAMMERS AND CUT OFF TOOLS

PART NO.	DESCRIPTION		SIZE	QTY
218072	Dr. Air Drill Reversible UT5825K Max RPM 1800	A	3/8"	1
218080	Dr. Air Ratchet 50ft LBS	B	3/8"	1
218100	Dr. Air Ratchet 50ft LBS	B	1/2"	1
218210	Air Hammer	C	190mm	1
218300	Cut Off Tool	D	N/A	



AIR TOOL ACCESSORIES

WHIP HOSE

PART NO.	DESCRIPTION		SIZE	QTY
218500	Leader/Whip Hose	E	1/4"	1
218510	Leader/Whip Hose	E	3/8"	1
218520	Leader/Whip Hose	E	1/2"	1



PRESSURE GAUGES AND MOISTURE SEPARATOR COMPONENTS

PART NO.	DESCRIPTION		QTY
218600	1/2" Filter	F	1
218620	1/2" Lubricator	G	1
218640	1/2" Regulator	H	1
218700	Pressure Gauge Glycerine 1/4" BSP (63mm-0-200psi) Bottom Entrance	I	1
218720	Pressure Gauge 1/4" BSP (50mm-0-290psi) Bottom Entrance	I	1
218740	Pressure Gauge 1/4" BSP (50mm-0-174psi) Back Entrance	I	1
218760	Pressure Gauge 1/8" BSP (50mm-0-174psi) Back Entrance	I	1

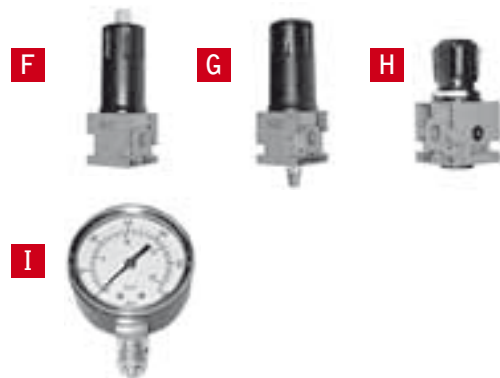

Why not visit
our website at
auto4.co.uk

■ BLOW GUN

- Manufactured from high quality die-cast alloy, giving the tool a long trouble-free life
- Robust/compact design
- Supplied with interchangeable conical and safety nozzles
- Outlet pressure on blowguns should not exceed 28lbf/in²; it is therefore recommended that an in-line regulator be fitted to your air system

PART NO.	DESCRIPTION		QTY
218800	Blow Gun Safety Nozzle	A	1
218820	Blow Gun Plastic	B	1

■ INFLATION GAUGES

PART NO.	DESCRIPTION		QTY
005000	AFG4H04 Hi-FLO MK4 AirLine Gauge Single Clip On Connector	C	1
005001	ALG3H03 Hi-FLO MK3 Airline Gauge Twin Hold On Connector	D	1
005010	AFG1H08 Dial Airline Gauge Single Clip On Connector	E	1
005020	Eurodainu Dial Airline Gauge Single Clip On Connector	F	1
005042	ALG3H061 Hi-FLO MK3 Airline Gauge Single Clip On Connector	G	1
005054	AFG4H05 Hi-FLO MK4 Airline Gauge Twin Clip On Connector	H	1
005056	AFG4H06 Hi-FLO MK4 Airline Gauge Twin Clip On Connector	I	1
005059	AFG5H36 Hi-FLO MK4 Airline Gauge Twin Clip On Connector 12'	J	1
005072	DAC404 Digital Tyre Inflator 0.53m Hose Single Clip On	J	1
005076	DAC406 Digital Inflation Gauge 2.7m Hose Twin Clip On	K	1

■ DIGITAL AIR GAUGE

- Inflating and checking pressure of motorcycles, light trucks and trucks
- Graduation from 1.45 to 145 Psi
- Rotating nipples (air inlet/outlet) for simple, easy handling
- Fast pressure adjustment
- Accurate digital display, fast easy readout
- Shock proof ABS material, water tight glass shield

PART NO.	DESCRIPTION		QTY
005200	Digital Air Digital Inflation Gauge	K	1



■ ACCURA QUBE ELECTRONIC TYRE INFLATOR

- 3 modes in one inflator
 - Mode 1 - Standard inflate / deflate
 - Mode 2 - Tyreshop mode with overpressure
 - Mode 3 - N2 fill and air to N2 Conversion
- Electronic pressure preset
- Auto-start inflation
- Touch screen technology
- Clear display for easy customer usage
- Space-saving and lightweight design
- Robust, high reliability engineering plastic housing
- Ceramic sensor - accuracy to +/- 0.5% of full scale reading
- 230V, 100V/120V and 12V versions
- Can inflate accurately with hoses up to 50m in length
- With moulded AC power cord for geographic regions

D



PART NO.	DESCRIPTION	QTY
005270	Accura Qube Electronic Tyre Inflator D	1

■ MASTAIR GAUGE

- Inflating and checking pressure of motorcycles, passenger cars, trucks and earthmover
- Double graduation from 0.7 to 12 bar and 10 to 170 Psi

PART NO.	DESCRIPTION	QTY
005300	Mastair Inflation Gauge Car and Truck C	1
005320	Mastair Inflation Gauge Earthmover C	1

C



■ MAESTRO GAUGE

- Inflating and checking pressure of motorcycles, passenger cars and light trucks
- Double graduation from 0.7 to 6 bar and 10 to 85 Psi

PART NO.	DESCRIPTION	QTY
005400	Maestro Inflation Gauge D	1

D



■ TYRE INFLATION DEVICES LARGE BORE

PART NO.	DESCRIPTION	QTY
503320	Inflation Device Extra Heavy Duty c/w Earthmover (Slide Type) Chuck G	1
503360	Eurodainu Gauge c/w 1.5m Hose Earthmover (Slide Type) Chuck	1

G



DRIVEN BY AIR.



Essential Tyreshop Equipment



Introducing...

ACCURA® MK4 Digital Tyre Inflator

Robust, lightweight, accurate, versatile
...and works in the dark

Also available:



AIRFORCE® MK4 Tyre Inflator

- Larger viewing window
- Accurate and Lightweight
- Biomorphic Shape



Professional Air Tools

- Lightweight
- Low vibration
- High performance



Dropout® Water Remover

- >99.9999% liquid water removal
- 1 micron particulate removal
- Built-in auto-drain



QUBE Tyre Inflator

- Cost effective and accurate
- Small compact design
- 3 pre-selectable application settings



ACCURA D12 Tyre Inflator

- Low and simple maintenance
- Reduced tyre inflation costs
- Guaranteed accuracy

■ PRESSURE GAUGES

PART NO.	DESCRIPTION		QTY
207000	Pocket Type Car Pressure Gauge 6-50psi In Line Head	A	1
207020	Commercial Pressure Gauge 10-120psi	B	1
207040	Pressure Gauge Dual 10-120psi	C	1
207060	Universal Pressure Gauge 10-160psi	D	1
207070	Universal Pressure Gauge 10-150psi - Chrome	E	1
207120	Digital Pressure/Tread Gauge	F	1
207126	Digital Pressure Gauge 5-100 Psi	G	1
207140	P/Gauge Dial 0-170psi	H	1
207160	P/Gauge Digital Dial Dual Foot 0 - 170 Psi	I	1
207200	Eurodaira Pressure Gauge 1781-1	J	1
503160	Pressure Gauge Straight Pencil	K	1
503180	Pressure Gauge Swivel Foot	L	1
503200	Dial Gauge c/w Commerical Connector	M	1
503220	Dial Gauge c/w L/B Connector	MM	1
503240	Dial Master Air Liquid	N	1
503260	L/B Cap Gauge	O	1

■ CONNECTORS

PART NO.	DESCRIPTION		QTY
208000	Connector Euro Style Open End - 6mm Hose	P	1
208010	Connector Euro Style Open End - 8mm Hose	P	1
208020	Single Clip On Connector 3/16" Hose Open End	Q	1
208040	Single Clip On Connector 3/16" Hose Closed End	Q	1
208050	Single Clip On Connector 1/4" Hose Open End	Q	1
208052	Single Clip On Connector 1/4" Hose Closed End	Q	1
208060	Twin Clip On Connector O/E	R	1
208080	Twin Clip On Connector C/E	S	1
208100	Twin Push On Connector O/E	T	1
208120	Twin Push On Connector C/E	U	1
208180	Clip On Chuck - Commercial	V	1
208400	Wing Nut Coupling 6mm ID	W	1
208402	Wing Nut Coupling 8mm ID	W	1
503100	L/B Air Chuck Euro Style	X	1

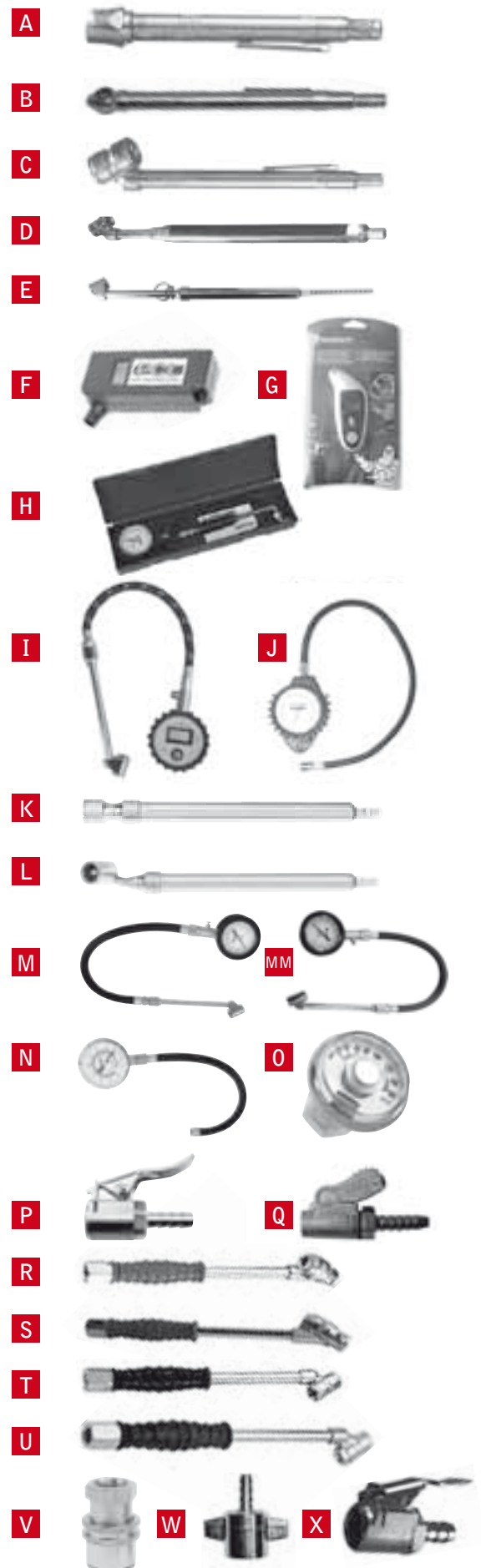

CONNECTORS (CONTINUED)

PART NO.	DESCRIPTION		QTY
503110	L/B Threaded Snap On Connector	Y	1
503120	Clip On Air Chuck (Closed) Valve	Z	1
503122	4660A L/B Chuck Premium	Z	1



CONNECTOR REPAIR KITS

PART NO.	DESCRIPTION		QTY
208140	Twin Clip On Connector Service Kit (Open End)	A	1
208160	Twin Clip On Connector Service Kit (Closed End)	A	1
503140	Earthmover (Slide Type) Chuck Repair Kit	B	1



STANDARD HOSE

PART NO.	DESCRIPTION		QTY
005500	MK3 Armoured Hose Only	C	1
005520	MK3 Armoured Hose c/w Single Connector	C	1
005540	MK3 Armoured Hose Only 6ft	D	1
005560	RHA2033 2.7m Hose with Tailpiece	D	1
005610	Hose & Chuck For Std Eurodair Gauge 3m	E	1
005620	Hose c/w Chuck For Mastair Gauge 1.5m	F	1
005640	Hose c/w E/M Clip On Chuck 3m	F	1

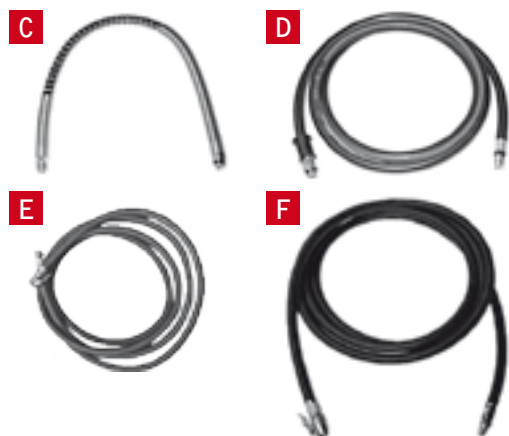

ARMOURED AND HEAVY DUTY HOSE

PART NO.	DESCRIPTION		QTY
004000	6mm (1/4") Diameter Hose 15m	G	1
004010	6mm (1/4") Diameter Hose 30m	G	1
004014	6mm (1/4") Diameter Hose 50m	G	1
004016	6mm (1/4") Diameter Hose 100m	G	1
004020	10mm (3/8") Diameter Hose 15m	G	1
004030	10mm (3/8") Diameter Hose 30m	G	1
004034	10mm (3/8") Diameter Hose 50m	G	1
004036	10mm (3/8") Diameter Hose 100m	G	1
004040	13mm (1/2") Diameter Hose 15m	G	1
004050	13mm (1/2") Diameter Hose 30m	G	1
004054	13mm (1/2") Diameter Hose 50m	G	1
004056	13mm (1/2") Diameter Hose 100m	G	1
004080	6mm (1/4") x 15m Hose c/w Fittings	H	1
004100	10mm (3/8") x 15m Hose c/w Fittings	H	1
004104	10mm (3/8") x 30m Hose c/w Fittings	H	1
004120	13mm (1/2") x 15m Hose c/w Fittings	H	1
004124	13mm (1/2") x 30m Hose c/w Fittings	H	1
004300	10mm (3/8") x 10m Airline Hose c/w Fittings	H	1



ARMoured AND HEAVY DUTY HOSE (CONTINUED)

PART NO.	DESCRIPTION		QTY
004340	10mm (3/8") x 20m Airline Hose c/w Fittings	H	1
004380	13mm (1/2") x 10m Airline Hose c/w Fittings	H	1
004420	13mm (1/2") x 20m Airline Hose c/w Fittings	H	1
004700	Tyre Filling Hose 15m	I	1
MA901	CEJN Hi-Vis Hose Assembly	J	1

POLYCOIL HOSE AND HOSE REELS

PART NO.	DESCRIPTION		QTY
004070	8mm (5/16") Polycoil Hose Kit	K	1
004620	Hose Reel 3/8" ID x 20m	L	1
004630	Hose Reel 1/2" ID x 18m	L	1
004690	Hose Reel DIY 3/8" ID x 15m	M	1



COUPLINGS AND ADAPTORS

AIRFLOW COUPLING

- The original quick release Airflow coupling with over 50 years of design enhancements
- Manufactured in the UK to the highest quality standards
- Steel construction - robust and hardwearing, ideal for the use in the engineering/workshop environment
- Stainless springs and bolts - provides additional corrosion and wear resistance
- Positive locking mechanism

PART NO.	DESCRIPTION		QTY
209000	1/4" BSP Female Coupler	A	1
209010	1/4" BSP Male Coupler	B	1
209012	3/8" BSP Female Coupler	A	1

VERTEX COUPLINGS

- The original quick release Airflow coupling with over 50 years of design enhancements
- These quick release couplings have a double action feature which makes them ideal for trailing hose applications in garage workshops and tyreshop environments
- Incorporates all the features of the Airflow coupling
- Steel construction with corrosive resistant finish - robust and hardwearing
- Protective shoulder prevents dirt penetration and accidental disconnection

PART NO.	DESCRIPTION		QTY
209020	1/4" BSP Female Vertex Coupler	C	1
209030	3/8" BSP Female Vertex Coupler	C	1
209040	1/4" BSP Male Vertex Coupler	D	1
209050	1/2" BSP Female Vertex Coupler	E	1
209054	1/2" BSP Male Vertex Coupler	F	1



HOSE CONNECTORS - HOSE TAIL ADAPTORS

PART NO.	DESCRIPTION		QTY
211000	1/4" BSP Male Thread 1/4" Hose	C	1
211002	1/4" BSP Male Thread 5/16" Hose		1
211020	1/4" BSP Male Thread 3/8" Hose	D	1
211040	1/4" BSP Male Thread 1/2" Hose	E	1
211129	3/8" BSP Male Thread 1/4" Hose		1
211130	3/8" BSP Male Thread 3/8" Hose		1
211140	3/8" BSP Male Thread 1/2" Hose		1
211150	1/2" BSP Male Thread 3/8" Hose		1
211160	1/2" BSP Male Thread 1/2" Hose		1

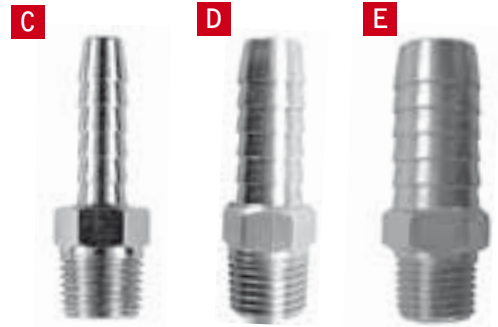

STANDARD ADAPTOR

- The standard adaptor is suitable for most workshop compressed air applications, design and manufactured alongside PCL standard couplings, this range of standard adaptors has become the benchmark in the UK for quality and reliability
- Used in most workshop/garage environments
- Wide choice of thread and bore sizes
- Used with Airflow, Vertex, twin, non-corrodible and standard safety couplings all highlighted in this directory
- Case hardened for longer life

PART NO.	DESCRIPTION		QTY
211060	1/4" BSP Male Thread Adaptor	F	1
211080	1/4" BSP Female Thread Adaptor	G	1
211090	3/8" BSP Male Thread Adaptor		1
211092	3/8" BSP Female Thread Adaptor		1
211100	1/4" Hose Tailpiece Adaptor	H	1
211110	5/16" Hose Tailpiece Adaptor		1
211120	3/8" Hose Tailpiece Adaptor		1



HOSE REPAIR COUPLINGS

PART NO.	DESCRIPTION		QTY
212000	Double Ended Hose Connector 1/4" Hose	I	1
212010	Double Ended Hose Connector 5/16" Hose		1
212020	Double Ended Hose Connector 3/8" Hose		1
212040	Double Ended Hose Connector 1/2" Hose		1



100 SERIES COUPLINGS

This traditional PCL 100 series range of couplings and adaptors offer greater airflow characteristics for the longer portable air tool applications in garage workshops and tyre shop environments.

- The hardened steel shoulder prevents accidental disconnection
- Secure locking device
- Swivel feature prevents kinking of the hose
- Specially designed valve and large aperture provide maximum air flow rates

PART NO.	DESCRIPTION		QTY
209060	1/2" BSP Female Coupler	A	1
209070	3/8" BSP Female Coupler	A	1
209080	1/2" BSP Male Coupler	B	1
209090	3/8" BSP Male Coupler	B	1



100 SERIES ADAPTORS

- For use with 100 series couplings
- Corrosive resistant finish
- Case hardened for longer life

PART NO.	DESCRIPTION	QTY
211170	3/8" BSP Male Thread Adaptor	1
211180	1/2" BSP Male Thread Adaptor	C 1
211190	3/8" Hose Tailpiece Adaptor	1
211200	1/2" Hose Tailpiece Adaptor	D 1
211220	3/8" BSP Female Thread Adaptor	1

C



D



REDUCING AND DOUBLE UNIONS (MALE TO MALE)

PART NO.	DESCRIPTION	QTY
213020	3/8" to 1/4" BSP Thread Reducing Union	1
213040	1/2" to 1/4" BSP Thread Reducing Union	E 1
213050	1/2" to 3/8" BSP Thread Reducing Union	1
213000	1/4" BSP Thread Double Union	F 1
213030	3/8" BSP Thread Double Union	F 1
213060	1/2" BSP Thread Double Union	F 1

E



F



REDUCING BUSH (MALE TO FEMALE)

PART NO.	DESCRIPTION	QTY
213200	3/8" BSP Male to 1/4" BSP Female Thread Reducer	1
213220	1/2" BSP Male to 1/4" BSP Female Thread Reducer	1
213240	1/2" BSP Male to 3/8" BSP Female Thread Reducer	G 1

G



PARALLEL SOCKETS

PART NO.	DESCRIPTION	QTY
213500	1/4" BSP Female Thread	H 1
213510	3/8" BSP Female Thread	H 1
213520	1/2" BSP Female Thread	H 1
213540	1/4" BSP Female 3/8" BSP Female Thread Reducing Union	1
213550	1/4" BSP Female 1/2" BSP Female Thread Reducing Union	1
213560	3/8" BSP Female 1/2" BSP Female Thread Reducing Union	1

H



TWIN COUPLINGS

PART NO.	DESCRIPTION	QTY
210000	1/4" BSP Vertex Twin Coupling	A 1
210020	1/2" BSP 100 Series Twin Coupling	1
210040	1/4" BSP Twin Coupling Body Only	B 1
210060	1/2" BSP Twin Coupling Body Only	B 1

A



B



■ SCHRADER COUPLINGS

- Genuine Schrader couplings and adaptors, manufactured by Parker, generally suitable for most fixed compressed air applications where this Schrader adaptor profile is required
- Twist locking feature prevents accidental disconnection
- When coupled, the adaptor can swivel, thereby eliminating kinking of hose

PART NO.	DESCRIPTION		QTY
213600	Standard Schrader Coupling 1/4" Female Thread	C	1
213602	Standard Schrader Coupling 1/4" Male Thread	D	1
213604	Heavy Duty Schrader Coupling 1/2" Female Thread	E	1



■ SCHRADER ADAPTORS

- For use with Schrader couplings
- Corrosive resistant finish
- Case hardened for longer life

PART NO.	DESCRIPTION		QTY
213610	Standard 1/4" Male Thread Schrader Adaptor	F	1
213612	Standard 1/4" Female Thread Schrader Adaptor	G	1
213614	Standard 1/4" Hose Tailpiece Schrader Adaptor	H	1
213616	Standard 5/16" Hose Tailpiece Schrader Adaptor	H	1
213618	Standard 3/8" Hose Tailpiece Schrader Adaptor	H	1
213622	Heavy Duty 1/2" Hose Tailpiece Schrader Adaptor	I	1



■ CEJN COUPLINGS AND ADAPTORS

PART NO.	DESCRIPTION		QTY
MC104102005	CEJN 13mm 1/2" Hose Barb CEJN 410 New E-Safe Coupling	J	1
MC104102155	CEJN 1/2" BSP Male Thread CEJN 410 New E-Safe Coupling	K	1
MC104102205	CEJN 1/2" BSP Female Thread CEJN 410 New E-Safe Coupling	L	1
MC104105005	CEJN 13mm 1/2" Hose Barb CEJN 410 Nipple	M	
MC104105152	CEJN 1/4" BSP Male Thread CEJN 410 Nipple	N	
MC104105154	CEJN 3/8" BSP Male Thread CEJN 410 Nipple	O	
MC104105155	CEJN 1/2" BSP Male Thread CEJN 410 Nipple	O	
MC104105205	CEJN 1/2" BSP Female Thread CEJN 410 Nipple	P	



follow us on

twitter

@Auto4Ltd

HOSE CLIPS

PART NO.	DESCRIPTION		QTY
205000	Hose Clip 000 9.5-12mm	J	1
205005	Hose Clip M00 11-16mm	J	1
205010	Hose Clip 00 13-20mm	J	1
205020	Hose Clip 0 16-22mm	J	1
205025	Hose Clip 0X 18-25mm	J	1
205210	Hose Clips S/Steel 8-12mm	J	10
205214	Hose Clips S/Steel 9-16mm	J	10
205222	Hose Clips S/Steel 12-20mm	J	10
205226	Hose Clips S/Steel 16-25mm	J	10
205230	Hose Clips S/Steel 20-32mm	J	10
205234	Hose Clips S/Steel 25-40mm	J	10
205238	Hose Clips S/Steel 32-50mm	J	10
205242	Hose Clips S/Steel 46-60mm	J	10
205246	Hose Clips S/Steel 50-70mm	J	10
205250	Hose Clips S/Steel 60-80mm	J	10
205254	Hose Clips S/Steel 70-90mm	J	10
205258	Hose Clips S/Steel 80-100mm	J	10



'O' CLIPS

PART NO.	DESCRIPTION		QTY
205040	'O' Clip 13-15mm	A	1
205050	'O' Clip 15-17mm		1
205060	'O' Clip 17-20mm	B	1
205080	'O' Clip 20-23mm	C	1

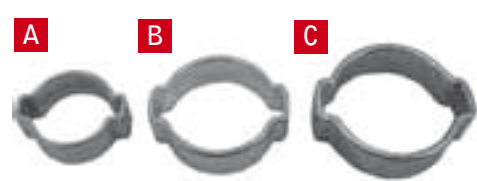

PTFE TAPE

PART NO.	DESCRIPTION		QTY
206000	PTFE Tape	D	1



TUBING

PART NO.	DESCRIPTION		QTY
FE40300	Overbraid Fuel Hose 3.5mm x 5m	E	1
FE40820	Brake Pipe Fittings 3/16 Nuts 10x1.00mm Short Male	F	50
FE41920	JG Speedfit Couplings Straight 6mm	G	10
FE41930	JG Speedfit Couplings Straight 8mm	G	15
FE41940	JG Speedfit Couplings Straight 10mm	G	5
FE41950	JG Speedfit Couplings Straight 12mm	G	5



Why not visit
our website at
auto4.co.uk

EXHAUST CLAMPS

PART NO.	DESCRIPTION		QTY
FC24050	Exhaust Clamps 45mm (1.3/4")	H	10
FC24060	Exhaust Clamps 48mm (1.7/8")	H	10
FC24070	Exhaust U Clamps - 51mm (2")	H	10
FC24080	Exhaust Clamps 54mm (2.1/8")	H	10
FC24090	Exhaust Clamps 57mm (2.1/4")	H	10

H



REGROOVERS, BLADES AND ACCESSORIES

RILLFIT 6

- Hitech toroidal power transformer with thermoswitch for safe and powerful non stop cutting
- Super flexible connection-cable, ergonomic and most operator friendly
- Ergonomic handgrip
- More water resistant transformer casting and high standard temperature preset-switch
- Additional blade adjustment pattern
- Compatible with existing Rillcut blades
- TÜV & CE certificated

REGROOVERS, BLADES AND ACCESSORIES

PART NO.	DESCRIPTION		QTY
007120	Rillfit 6 Professional Regroover (230v)	A	1
007140	Rillfit 6 Professional Regroover (110v)	A	1
007660	Regroover Depth Gauge	B	1
007920	Rillfit 6 Connection Cable including Cable Socket & Rubber Tulle	C	1
007932	Rillfit 6 Blade Head Complete	D	1
007940	Rillfit 6 Blade Holder Set Complete	E	1

A

B



C



D

E



follow us on

twitter

@Auto4Ltd

STANDARD AND TRUCKSTAR REGROOVERS - PSO

PART NO.	DESCRIPTION		QTY
007200	Truckstar Regroover (230v) - Digital Control	F	1
007220	Standard Regroover (230v) - Rotary Switch	G	1
007300	Truckstar Regroover (110v) - Digital Control	F	1
007320	Standard Regroover (110v) - Rotary Switch	G	1
007400	Regrooving Stand	H	1
M15115	Blade Clamp Block	I	Pair
M15119	Blade Block	J	Pair
M15011/E	Truckstar Cutting Head	K	1
M15011/ST	Standard Cutting Head	K	1

- PSO have been producing quality regroovers for more than twenty five years in Europe
- Both Standard and Truckstar regroovers have robust steel transformer case, lightweight cutting head and 3 pin plug
- Truckstar has a digital variable heat setting that will allow for more precise cutting and automatic cut off after 15 minutes of no use
- Truckstar has a more powerful 500w transformer and upgraded circuit board (the standard version is 370w)

WIDE REGROOVER BLADES - RILLFIT

PART NO.	CUT WIDTH (MM)	CUT DEPTH (MM)	SIZE	QTY
214000	W1 3-4	7	L	20
214020	W2 5-6	8	L	20
214040	W3 6-8	10	L	20
214060	W4 9-10	14	L	20
214080	W5 10-14	16	L	20
214100	W6 17-20	16	L	10

ROUND REGROOVER BLADES - RILLFIT

PART NO.	CUT WIDTH (MM)	CUT DEPTH (MM)	SIZE	QTY
214200	R1 3-4	7	M	20
214220	R2 5-6	8	M	20
214240	R3 6-8	10	M	20
214260	R4 9-10	14	M	20
214280	R5 10-14	16	M	20

ROUND REGROOVER BLADES - PSO

PART NO.	CUT WIDTH (MM)	CUT DEPTH (MM)	SIZE	QTY
214420	R2 5-6	8	M	20
214440	R3 6-8	10	M	20
214460	R4 9-10	14	M	20
214480	R5 10-14	16	M	20



PSO WIDE REGROOVER BLADES ALSO AVAILABLE ON REQUEST

BEAD BREAKING TOOLS

PART NO.	DESCRIPTION	SIZE	QTY
008000	BBO Bead Breaker	10"/254mm	1
008020	BBO Bead Breaker	C 20"/508mm	1
215000	Bead Breaker Double Handed	A	1
215020	Bead Breaker Single	B	1
215260	EVA Bead Breaker	D	1
215280	EVA Super Slick'em	E 1 Gallon	1
215300	Bead Buster Tool	F	1
215400	Ramrod Evo All-Rim Bead breaker	G	1
215420	EVA Bead Breaker	H	1

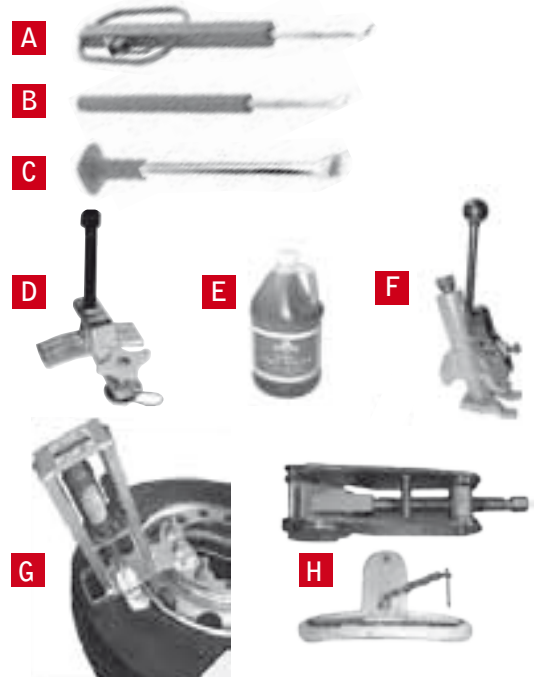

TYRE SERVICE EQUIPMENT

PART NO.	DESCRIPTION	QTY
215040	Tyre Inspection Spreader Manual Bench Mounted	1
215057	Tyre Inspection Spreader Truck/Earthmover T-54	1
215060	Tyre Inspection Spreader Scissor Type	1
215100	Tyre Stool 3 Leg Heavy Duty	1
215140	Tyre Test Tank	1
215142	Tyre Test Tank c/w Spindle & 2 Wheels	1
215150	Replacement Tyre Test Tank Insert	1
215155	Poly Tyre Test Tank 50 Gallon	1
222600	Bead Wedge	1
222620	Bead Keeper - Plated Finish	1
222640	Bead Holder/ F-Clamp	1



BEAD SEATERS

A rubber ring for mounting problematic radial or crossply tyres. The lubricated bead seater forms a seal between the rim and tyre allowing the inflation pressure to force the beads into the wheel rim flange.

PART NO.	DESCRIPTION	SIZE	QTY
215160	Bead Seater	Q 13"	1
215180	Bead Seater	Q 14-15"	1
215200	Bead Seater	16.5"-17.5"	1
215220	Bead Seater	19.5"	1
215240	Bead Seater	22.5"	1



BEAD CHEETAHS

PART NO.	DESCRIPTION	SIZE	QTY	
009000	Cheetah Bead Seater c/w Safety Glasses/Ear Plugs	R	18.97 Litre	1
009002	Cheetah Bead Seater (Black) - Value	S	20 Litre	1
009020	Cheetah Bead Seater	T	38 Litre	1
009040	Gaither Bead "Bazooka"	U	6 Litre	1



BEAD CHEETAH ACCESSORIES

PART NO.	DESCRIPTION	SIZE	QTY
009500	Bush	A	1
009520	Pressure Gauge	B	1
009540	Air Intake Valve 1/4"	C	1
009560	Pressure Release Valve	D	1
009600	Elbow	E	1
009620	Spout	F	1
009640	Ball Valve 1.1/2"	G	1

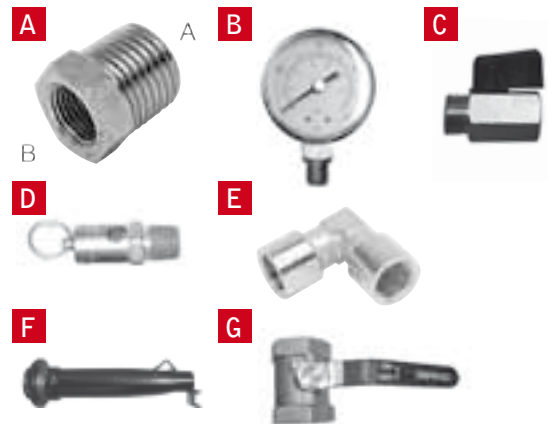

PORTABLE AND STATIC SAFETY CAGES

We have a range of sizes available, please call our sales team or speak to your local sales representative for further information.

PART NO.	DESCRIPTION	SIZE	QTY	
215120	Portable Safety Cage	H	1	
226340	Static Safety Cage Small (Open Sided)	I	1240 x 1240 x 610mm	1
226345	Static Safety Cage Small (Closed Sided)	J	1240 x 1240 x 610mm	1
226360	Static Safety Cage 915mm x 915mm x 610mm	I	915mm x 915mm x 610mm	1



Why not visit our website at auto4.co.uk

Gaither™

PROFESSIONAL EQUIPMENT
GAITHERTOOL.COM



12880E - BEAD SAVER

GTABB01



BEAD BAZOOKA® BB6L
PATENT PENDING

BEAD BAZOOKA® GB38L
PATENT PENDING

BEAD BAZOOKA® BB12L
PATENT PENDING



RDB20A - MAX 20T



WINNTEC

WINNTEC.NET



Y471105 - 220KG

Y471180

Y432020 - 20T

Y451205 - 12T

Y420303 - 3T

Y4711147HD

TORQUE WRENCHES

Norbar were the first company in Britain to commercially manufacture torque wrenches and are renowned in the industry for their high quality and precision.

- Robust construction gives accurate results to +/- 4%
- Large break angle improves accuracy by reducing the possibility of over torquing
- Dual scale Nm and lbf-ft
- Every tool comes in its own moulded case with calibration certificate

PART NO.	DESCRIPTION	SIZE	QTY	
009725	1/2" Dr.Torque Wrench Norbar	A	60-300 Nm	1
009732	1/2" Dr.Torque Wrench Norbar	B	60-340 Nm	1
009740	1" Dr.Torque Wrench Norbar	C	200-800 Nm	1
009760	1" Dr.Torque Wrench Norbar	C	300-1000 Nm	1
009780	1" Dr.Torque Wrench Norbar	C	700-1500 Nm	1
009910	Torque Multiplier Set Wrench	D		1

TORQUE WRENCH ACCESSORIES

PART NO.	DESCRIPTION	QTY	
009080	1" Sq. Dr. Male x 1" Sq. Dr. Male Torque Wrench Adaptor	1	
009100	1" Sq. Dr. Male x 3/4" Sq. Dr. Male Torque Wrench Adaptor	E	1
009110	3/4" Sq. Dr. Male x 3/4" Sq. Dr. Male Torque Wrench Adaptor		1
009120	1/2" Sq. Dr. Male x 1/2" Sq. Dr. Male Torque Wrench Adaptor		1
009140	1/2" Sq. Dr. Mushroom Head	F	1

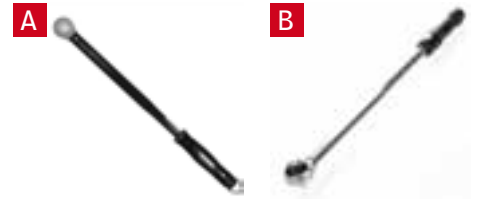

JACKS

Winntec Jacks

Winntec line of tools and jacks are specifically designed for the service professional. Auto4 carry a number of high quality Winnotec Jacks at very affordable prices.

Weber Jacks

Weber Uk has been firmly established in the UK aftermarket for a number of years and is well known for their quality and reliability.

Our range of jacks allows customers to choose the right product for their pocket and level of use.

STANDARD TROLLEY JACKS

PART NO.	DESCRIPTION	QTY	
010002	3 Ton Trolley Jack	G	1
010004	3 Ton Trolley Jack 420303 Winnotec	H	1
010020	2 Ton Weber Trolley Jack Standard	I	1
010026	2 Ton Trolley Jack 420210 Winnotec	J	1

Norbar is devoted exclusively to the design, development and production of torque tightening equipment



Dedicated specialists: Our products are designed and manufactured in the United Kingdom; this includes a range of torque wrenches, multipliers, measuring equipment, and engineer to order solutions.

Automotive torque solutions: From vehicle manufacturing through to the repair and maintenance of all types of on and off-road vehicles, Norbar's role in the automotive industry ensures that you can provide your customers with accurately bolted joints.

INDUSTRIAL WRENCHES

Robust torque wrenches with an unmistakable torque break point

Ideal for commercial vehicle maintenance and other torque applications with models available from 80N·m to 2000N·m



PROFESSIONAL TORQUE WRENCHES

Setting the standard for accuracy and ease of use

Norbar's Professional Torque Wrench range has become one of the most popular wrench ranges available worldwide



HANDTORQUE® MULTIPLIERS

HandTorque® HT3 Multipliers are tough and versatile

Using the latest gearbox technology and materials to produce versatile and compact torque multipliers



Our commitment to you is to provide torque tools and instruments that are durable and maintain accuracy for longer than the alternatives, backed up by Norbar companies and distributors the world over.



NORBAR TORQUE TOOLS LTD

Wildmere Road, Banbury, Oxfordshire, OX16 3JU

New Sales: +44 (0) 1295 753600

www.norbar.com

After Sales: +44 (0) 1295 753635

COMPAC TROLLEY JACKS

Our Compac jacks are manufactured to the highest standards and designed with the professional garage mechanic's need for safety and performance in mind.

Our Jacks feature:

- 'Lift and twist' mechanism to prevent accidental lowering
- Overload valve to prevent overloading
- A protective cylinder jacket
- A solid gauge steel construction
- Heavy duty swivel casters for high weight bearing capacity

PART NO.	DESCRIPTION		QTY
010030	2 Ton Compac Trolley Jack	K	1
010042	2 Ton Compac Trolley Jack Long Ultra Low Entry	L	1
010050	3 Ton Compac Trolley Jack Long	M	1
010064	10 Ton Compac Bottle Jack	N	1
010102	15 Ton Compac Bottle Jack	N	1
010122	20 Ton Compac Bottle Jack	N	1



BOTTLE JACKS

PART NO.	DESCRIPTION		QTY
010060	10 Ton Weber Bottle Jack	O	1
010062	10 Ton Low Weber Bottle Jack	P	1
010100	15 Ton Weber Bottle Jack	O	1
010110	16 Ton Bottle Jack Value	Q	1
010120	20 Ton Weber Bottle Jack	O	1
010126	20 Ton Bottle Jack 412000 Winntec	R	1
010128	20 Ton Low Height Bottle Jack 412001 Winntec	S	1
010130	20 Ton Bottle Jack Value		1



AIR HYDRAULIC BOTTLE JACKS

PART NO.	DESCRIPTION		QTY
010202	20 Ton Weber MGH20 Air/Hydraulic Bottle Jack	T	1
010211	20 Ton Air/Hydraulic Bottle Jack AME	U	1
010212	20 Ton Air/Hydraulic Bottle Jack 432020 Winntec	V	1
010216	20 Ton Air/Hydraulic Bottle Jack c/w Trolley 432003 Winntec	W	1
010222	20 Ton Low Height Air/Hydraulic Bottle Jack Winntec	X	1



COMPAC WORKSHOP EQUIPMENT

HIGH QUALITY PRODUCTS SINCE 1946



STANDARD ON ALL COMPAC TROLLEY JACKS

- **Foot pedal** for quick approach to the jacking point in only 2-3 foot pumps.
- Built-in **safety lowering** control valve for safe lowering.
- Built-in pressure relief valve **prevents overloading**.
- Heavy duty fully welded structure in **high quality** steel.
- **Ergonomically** designed handle for operator comfort.
- 3 year factory **warranty**.

2 ton low height trolley jack



2T-C

2 ton trolley jack with extremely low chassis



2T-77

3 ton trolley jack ideal for vans and 4WDs

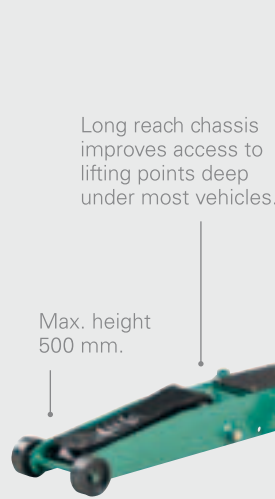

3T-C

1,5 ton high lift trolley jack - max. height 800 mm.



1,5T-HC

Universal transmission jacks capacity 300 kg or 525 kg

Accessory

McPherson strut support. 53012



Supports and holds the suspension strut when working on the wheel suspension

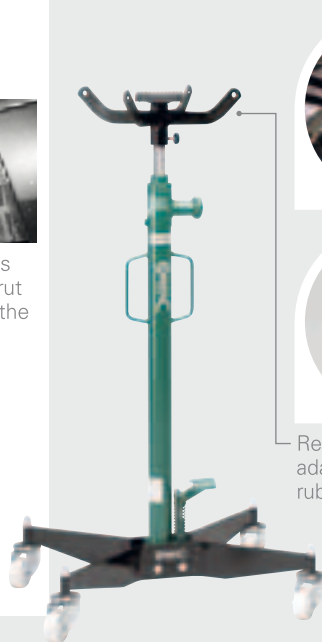

TJ 300



Reversible transmission adaptor with saddle and rubber pad.

TJ 525

Foot operated workshop presses 20 and 25 tons

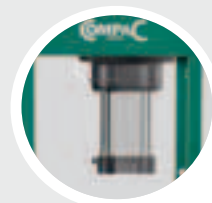

Moveable cylinder.

Very long stroke of 240 mm.



Foot operated air approach feature.

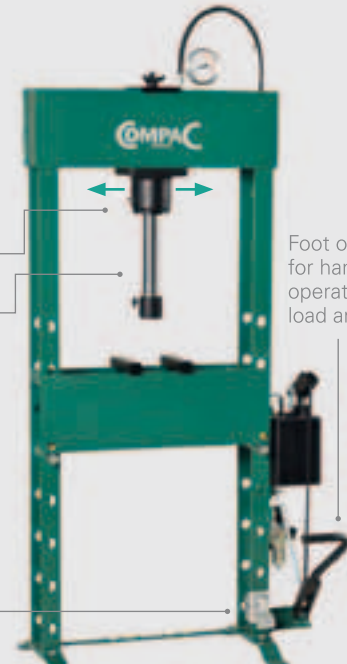

FP 20

FP 25

Compac Hydraulik A/S

Strandhusevej 43 // 7130 Juelsminde // Denmark
Tel: +45 75 69 37 22 // info@compac.dk // www.compac.dk



■ PNEUMATIC JACKS

These jacks are built with rubber and high resistance fabric membranes and thus have the advantage of not being equipped with sliding components and gaskets. In this way they are completely reliable, strong and maintenance free. All models are equipped with an overload valve calibrated to 10 Bar and a locking device to prevent the cylinder from descending during a pneumatic pressure loss.

PART NO.	DESCRIPTION	CAPACITY	QTY
010714	Air Jack 2 Bellows HBNXLO	A 2.5 Tonne	1
010715	Air Jack 2 Bellows Portable HXLO	2.5 Tonne	1
010717	Air Jack 3 Bellows HBN3	B 2.5 Tonne	1
010718	Air Jack 3 Bellows Portable H3	2.5 Tonne	1

■ AIR/HYDRAULIC TROLLEY JACKS

These jacks are built with high quality steel, with chromium coating on the external sliding parts, while the pneumatic parts are treated with an anti-corrosion process. The built-in safety valves avoid accidental overloads and prevent the load from dropping during a pneumatic pressure loss.

PART NO.	DESCRIPTION	CAP 1	CAP 2	QTY
010800	One Step Air Hydraulic Jack	30 Tonne	N/A	1
010810	One Step Air Hydraulic Portable Jack	E 30 Tonne	N/A	1
010814	One Step Air Hydraulic Jack	20 Tonne	N/A	1
010816	One Step Air Hydraulic Portable Jack	20 Tonne	N/A	1
010818	Two Step Air Hydraulic Jack	15 Tonne	30 Tonne	1
010820	Two Step Air Hydraulic Portable Jack	F 15 Tonne	30 Tonne	1
010830	Two Step Air Hydraulic Jack	10 Tonne	20 Tonne	1
010836	Two Step Air Hydraulic Portable Jack	10 Tonne	20 Tonne	1
010840	Two Step Air Hydraulic Jack	10 Tonne	20 Tonne	1
010842	Two Step Air Hydraulic Portable Jack	10 Tonne	20 Tonne	1

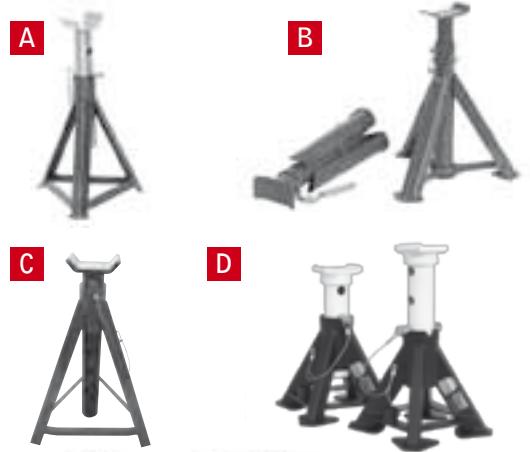

AXLE STANDS

PART NO.	DESCRIPTION	SIZE	QTY
010900	Axle Stand	A 2 Tonne	2
010906	Folding Axle Stands	B 2 Tonne	2
010910	Axle Stands	C 5 Tonne	2
010914	Axle Stands 7 Tonne Capacity Per Stand Short	D 7 Tonne	2
010920	Axle Stands	E 12 Tonne	2
010940	Extra High Axle Stands 4 Tonne Per Pair	F 4 Tonne	2

HAMMERS

PART NO.	DESCRIPTION	SIZE	QTY
216000	Rubber Mallet Heavy Duty	G 3lb/1.5 kg	1
216016	Club Hammer Fibre Glass Shaft 10"/254mm PREMIUM	H 2.5lb	1
216020	Club Hammer Fibre Glass Shaft 10"/254mm PREMIUM	I 4lb/1.81kg	1

Weber UK

WEBER UK LIMITED

Quality Engineered Hydraulic Equipment



WDK20



MGH-20



WS24L



AX12-230

Our High Quality Product Range includes:

*Bottle Jacks | Pit Jacks | King Pin Presses | Floor Presses and
Press Screen Protectors | Air Hydraulic Trolley Jacks | Air Bags |
Axle Stands and many more*



SERVICE

Weber UK offer a comprehensive repair and service facility for all our products from our warehouse in Halstead. We also have approved repairers across the country.



KNOWLEDGE

Weber UK has been supplying the automotive and industrial market for 40 years we have wealth of experience to be able to provide each customer with the right tool for the job. Contact Us today.



QUALITY

Our prime concern is one of quality and we aim to meet all requirements demanded by the recognised international standards authorities including the MOD. The company is NQA registered to ISO 9001:2008



sales@weberuk.com



www.weberuk.com



01787 476319

HAMMERS (CONTINUED)

PART NO.	DESCRIPTION	SIZE	QTY
216040	Club Hammer Fibre Glass Shaft 16"/406mm PREMIUM	I	4lb/1.81kg
216060	Sledge Hammer Fibre Glass Shaft 24"/610mm PREMIUM	I	7lb/3.18kg
216062	Sledge Hammer Fibre Glass Shaft 16"/406mm PREMIUM	I	7lb/3.18kg
216080	Sledge Hammer FG Shaft 30"/762mm PREMIUM	J	7lb/3.18kg
216090	Sledge Hammer FG Shaft 36"/914mm PREMIUM	J	10lb/4.54kg
216100	Sledge Hammer FG Shaft 36"/914mm PREMIUM	J	14lb/6.35kg
216102	Sledge Hammer FG Shaft 36"/914mm	K	14lb/6.35kg
216240	Ball Pein Hammer Fibre Glass Shaft	L	3lb/1.36kg
216400	Copper/Raw Hide Hammer	M	Size A, 1" Face
216420	Copper/Raw Hide Hammer	M	No.1, 1.1/4" Face
216440	Copper/Raw Hide Hammer	M	No.2, 1.1/2" Face
216460	Copper/Raw Hide Hammer	M	No.3, 1.3/4" Face
216470	Raw Hide/Raw Hide Hammer	N	No.3, 1.3/4" Face
216480	Copper/Raw Hide Hammer	M	No.4, 2" Face
216490	Raw Hide/Raw Hide Hammer	O	No.4, 2" Face



TOOLS

APPLICATORS AND KNIVES

PART NO.	DESCRIPTION	SIZE	QTY
217000	Tyrefit Paste Brush	A	N/A
217010	Paste Brush Professional H/D	B	N/A
217014	Heavy Duty Paste Brush	C	N/A
217030	Cotton Applicator	D	N/A
217040	Skiving Knife Standard	E	N/A
217050	Dexter Knife	F	N/A
011000	Skiving Knife Professional	G	6"/152mm
FK92400	Teng Retractable Trim Knife 1	H	N/A
FK92410	Blades Trim Knife 100	I	N/A
FK94670	Caulking Gun Heavy Duty	J	N/A

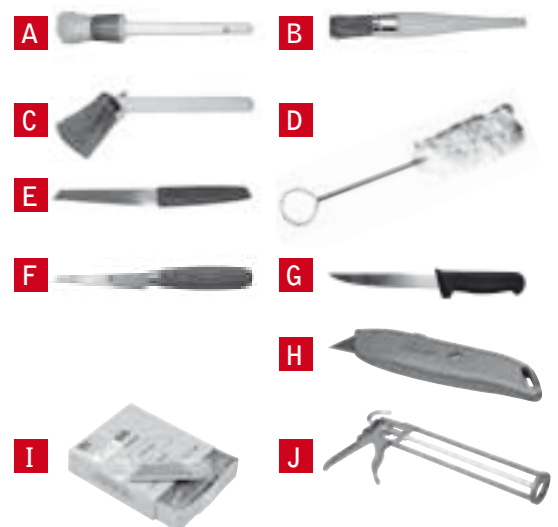

■ RASPS, AWLS, PROBES AND NEEDLE TOOLS

PART NO.	DESCRIPTION	SIZE	QTY
011120	Insertion Needle - Side Eye	K 151mm	1
011140	Insertion Needle - H/D Side	L N/A	1
051020	Bow Tie Needle Earthmover	V 205mm	1
051022	EM Sealastic Inserting Tool	W 230mm	1
051040	Hand Rasp Large Pistol Grip	Q 205mm	1
051100	Tyre Repair String Needle	CC 223mm	1
051140	Chrome 'T' Insertion Tool	DD N/A	1
051150	Chrome 'T' Insertion Tool Premium	N/A	1
051160	Open Eye Needle	EE 8"/203mm	1
051170	HD80 Replacement Closed Eye Needle	9"/229mm	1
217060	Awl/Probe Straight	M N/A	1
217070	Awl/Probe Puncture Repair Type	N N/A	1
217100	Tyre Rasp 3mm Diameter	O 90mm	1
217110	Tyre Rasp 6mm Diameter	P 100mm	1
217120	Reamer T Handle	N/A	1
217140	Stitcher	R 38mm x 2mm	1
217160	Stitcher	S 38mm x 3mm	1
217180	Buffer/Stitcher	T N/A	1
217240	Open Eye Needle	AA 4"	1
217260	Spiral Cement Tool	HH N/A	1
217280	Rubber Scraper	II N/A	1
217300	Insert Needle Side Eye	U 177mm	1
217320	Small Closed Eye Needle Tool	BB 4"/102mm	1
217330	Plug Patch Needle Tool		1
2-92701	Pulling Wire for Plug Patch	JJ N/A	1
2-92812	Insert Needle for ValkasealL10	X 75mm	1
2-92817	Spare Needle for Valkaseal	FF 75mm	1
2-92818	Spare Needle for Valkaseal	GG 100mm	1
2-92905	Insert Needle for ValkasealS10	Y N/A	1
2-92906	Insert Needle for ValkasealL14	Z 80mm	1

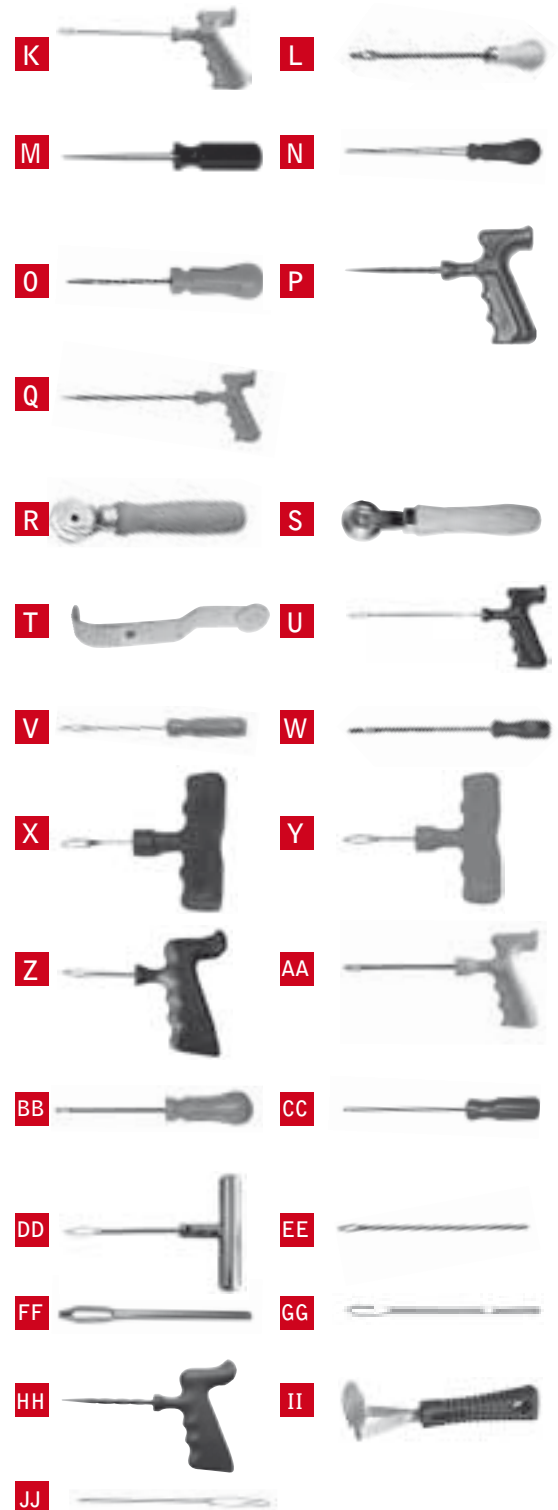

follow us on

twitter

@Auto4Ltd

■ WORKSHOP TOOLS

PART NO.	DESCRIPTION	SIZE	QTY
011010	Wire Cutters	C 8"/203mm	1
011020	Combi Pliers	D 7.1/2"	1
011022	Beta Combination Pliers	180mm	1
011032	Chrome Spanner Set 22 Pc	N/A	1
011040	Long Nose Pliers	F 8"/203mm	1
011042	Beta Long Nose Pliers	200mm	1
011048	Plier Sets 3 Pc Long Nose/ Combination/Diagonal	G 160mm	1
011050	Metal File Set 5 Piece	N/A	1
011060	Adjustable Spanner	H 12"/305mm	1
011061	Beta Adjustable Spanner	200mm	1
011066	Beta Pipe Wrench H/D	200mm	1
011067	Stillson Pipe Wrench	350mm	1
011080	Molegrips	I 10"/250mm	1
011082	Beta 1052-240 Adjustable Self Locking Pliers	J 240mm	1
011084	Beta Self Locking Pliers Straight Jaw	K 240mm	1
011088	Locking Plier Set 3 Pc 5/7/9"	L 127/178/229mm	1
011090	Vise Grips Curved Jaw	10"/250mm	1
011115	Stainless Steel Rule Graduated 1/16"	M 0.5mm - 300mm	1
217200	Wire Brush 4 Row	A N/A	1
217210	Beta Wire Brush	B N/A	1
217220	Wire Brush/Spid	B N/A	1
244160	Hub Cap Removal Tool	R	1
244180	Adhesive Weight Remover	S	1
244200	Cable Ties Grey	K 4.9mm 370mm	100
244210	Cable Ties Black	K 4.9mm 370mm	100
244280	Screwdriver Set 12 Piece	N	1
244300	Allen Key Set	O	1
244304	Hexagon Key Set mm 10 Pc		1
244310	Hex Torx Key Set 9 Pc Long Arm - T10/15/20/25/27/30/40/45/50	P	1
244313	4 Compartment Tilt Out Bin c/w bar	U	1
244320	18" Plastic Tool Box	Q	1
244336	Kneeling Mat	V	1
244360	Rechargeable Torch	T	1
244365	HT107LED LED Head Torch	W	1
244369	Rechargeable 360 Inspection Lamp 2W COB + 1W LED	X	1
244380	Heavy Duty Jump Leads 200 Amp		1
244396	Cable Reel 110v Freestanding 2 Socket	Y 25m	1
244500	Trigger Spray/Bottle Fluorinated	Z 500ml	1



WORKSHOP TOOLS CONTINUED

PART NO.	DESCRIPTION	SIZE	QTY	
244520	Trigger Oil Can	ZZ	250ml	1
244598	Car Wheel Chock Single	AA		1
244600	Commercial Wheel Chock Single	BB		1
244620	Rubber Support Blocks Set Of 3 Pairs	CC	40/70/120mm	6
FG66080	Measuring Jug Flexi Spout		5 Litre	1
FG66120	Measuring Jug	DD	5 Litre	1
FG66160	Chemical Resistant Pump Sprayer	EE	1 Litre	1
FK90040	Dormer HSS Twist Drills	FF	1/8"	10
FK90080	Dormer HSS Twist Drills	FF	3/16"	10
FK94950	General Paint Brushes		1"	10
FK94970	General Paint Brushes		2"	10
FK95080	Dormer HSS Twist Drills	FF	5.0mm	10
FX90700	Standard Twist Drills (Imperial)		1/8"	10
FX90740	Standard Twist Drills (Imperial)		3/16"	10

TYRE TREAD DEPTH GAUGES

TYRE TREAD DEPTH GAUGE CAR/TRUCK

PART NO.	DESCRIPTION	SIZE(MM)	QTY	
243160	Tyre Tread Depth Gauge Pencil Type	A	1-26	1
243170	Tyre Tread Depth Gauge Truck	B	0-25	1
243190	Digital Tread Depth Gauge		0-25	1

TYRE TREAD DEPTH GAUGE LARGE BORE

PART NO.	DESCRIPTION	SIZE(MM)	QTY	
503280	Tyre Tread Depth Gauge Pencil Type	C	8-192	1
503300	Tyre Tread Depth Gauge Professional	D	0-152	1

ASSORTMENTS

PART NO.	DESCRIPTION	QTY
FA01130	Self Tappers PZD Pan Screws	700
FA01140	Self Tappers PZD Pan Screws Large	330
FA01160	Self Tappers PZD Flange Screws Black	700
FA01700	Split Pins Imperial	1000
FA02220	ATO Blade Fuses (Standard)	80
FA02250	Insulated Wiring Terminals Push on	300
FA05000	Flat Bar 1.5m	10
FA05260	General Use Paint Brushes	10
FA05280	Quality Touch-up Paint Brushes	10
FA05800	JCS Hose Clips	50

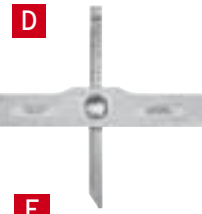
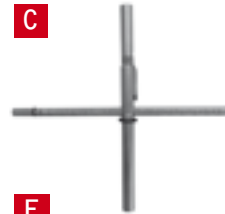

ELECTRICAL

PART NO.	DESCRIPTION	QTY
FB10320	Plug Fuses (Mains) 13 amp	50
FB10220K	ATO Blade Fuses 5 Amp Blue	A 25
FB10230K	ATO Blade Fuses 7.5 Amp Blue	A 25
FB10240K	ATO Blade Fuses 10 Amp Red	A 25
FB10250K	ATO Blade Fuses 15 Amp Blue	A 25
FB10260K	ATO Blade Fuses 20 Amp Yellow	A 25
FB10270K	ATO Blade Fuses 25 Amp Yellow	A 25
FB10280K	ATO Blade Fuses 30 Amp Green	A 25
FB10288	Mini Blade Fuses 5 Amp Brown	B 25
FB10290	Mini Blade Fuses 10 Amp Red	B 25
FB10291	Mini Blade Fuses 15 Amp Blue	B 25
FB10292	Mini Blade Fuses 20 Amp Yellow	B 25
FB10294	Mini Blade Fuses 30 Amp Green	B 25
FB10375	Blade Fuse Holders Splashproof	C 10
FB04480	448 Halogen Bulbs H1 P14.5s 12v 55w	D 1
FB04530	453 Halogen Bulbs H3 PK22s 12v 55w	E 1
FB04660	466 Halogen Bulbs H1 P14.5s 24v 70w	E 1
FB04720	472 Halogen Bulbs H4 P43t 12v 60/55w	E 1
FB04990	499 Halogen Bulbs H7 PX26d 12v 55w	E 1
FB01490	149 Side Light Bulbs SCC BA15s 24v 5w	F 10
FB03800	380 Stop and Tail Bulbs SBC BAY15d 12v 21/5w	F 10
FB16720	Alkaline Batteries AAAA 1.5v	G 6
FB16780	Energiser Lithium Coins CR2032 3v	H 5
FB11400	Twin 2 x 1mm 14/030 30m Wiring Cable - Black	I 1
FB11720	Battery Terminals HD 24v Pos +	J 10
FB13040	Red 6.3mm Female Spades F/Ins	K 100
FB13070	Red 4.0mm Male Bullets	L 100
FB13080	Red 4.0mm Female Sockets	M 100
FB13090	Red Female Butt Connectors	N 100
FB13330	Pre-insulated Terminals Blue 6.3mm Female Spades F/Ins	O 100
FB13350	Pre-insulated Terminals Blue 6.3mm Male Blades	100
FB13360	Pre-insulated Terminals Blue 5.0mm Male Bullets	100
FB13370	Pre-insulated Terminals Blue 5.0mm Female Sockets	100
FB13390	Pre-insulated Terminals Blue Female Butt Connectors	100
FB13460	Pre-insulated Terminals Blue 6.4mm Ring (OBA, 1/4")	P 100
FB13740	Heat Shrink Connectors Butts Red	Q 25
FB13760	Heat Shrink Connectors Butts Blue	Q 25
FB13780	Heat Shrink Connectors Butts Yellow	Q 10
FB14160	PTFE Sealing Tape 12mm x 12m	R 10
FB14170	Gaffer Tape Silver 50mm x 50m	R 2
FB14180	Gaffer Tape Black 50mm x 50m	R 2
FB14190	Self Amalgamating Tape 25mm x 5m Black	R 1
FB14200	Advance PVC Insulation Tape 19mm x 20m	R 10
FB14300	Nitto PVC Insulation Tape 19mm x 20m Black	R 10
FB12548	Metal Ties 40 to 110mm	S 10
FB12610	Adhesive Cable Clips 11.5mm	50
FH74900	7 Pin Caravan/Trailer 12v Plug	T 1



■ FASTENERS

PART NO.	DESCRIPTION		QTY
FF51882	HT Sets Flange Head M8 x 45mm		50
FF52130K	HT Setscrews (Metric) M6 x 25mm	A	50
FF52100K	HT Setscrews (Metric) M6 x 12mm	A	50
FF52160K	HT Setscrews (Metric) M6 x 40mm	A	50
FF52170K	HT Setscrews (Metric) M6 x 50mm	A	50
FF52195K	HT Setscrews (Metric) M8 x 16mm	A	50
FF52210K	HT Setscrews (Metric) M8 x 25mm	A	50
FF52220K	HT Setscrews (Metric) M8 x 30mm	A	50
FF52240K	HT Setscrews (Metric) M8 x 40mm	A	50
FF52260K	HT Setscrews (Metric) M8 x 50mm	A	50
FF52280	HT Setscrews (Metric) M8 x 75mm	A	50
FZ736750K	HT Setscrews (Metric) M8 x 80mm		50
FF52300K	HT Setscrews (Metric) M10 x 25mm	A	50
FF52330K	HT Setscrews (Metric) M10 x 45mm	A	50
FF52340	HT Setscrews (Metric) M10 x 50mm	A	50
FF52380	HT Setscrews (Metric) M10 x 80mm	A	50
FF52405	HT Setscrews (Metric) M12 x 30mm	A	50
FF52420	HT Setscrews (Metric) M12 x 40mm	A	50
FZ736766	HT Setscrews (Metric) M12 x 45mm		50
FF52430	HT Setscrews (Metric) M12 x 50mm	A	50
FF52440K	HT Setscrews (Metric) M12 x 80mm	A	50
FF53802K	HT Bolts (Metric) M8 x 40mm		50
FF53810	HT Bolts (Metric) M10 x 50mm		50
FF54330K	Steel Nuts (Metric) M6	B	50
FF54340K	Steel Nuts (Metric) M8	B	50
FF54350K	Steel Nuts (Metric) M10	B	50
FF54360K	Steel Nuts (Metric) M12	B	50
FF54410K	Serrated Flange Nuts (Metric) M6	C	50
FF54420K	Serrated Flange Nuts (Metric) M8	C	50
FF54430	Serrated Flange Nuts (Metric) M10	C	50
FF54440	Serrated Flange Nuts (Metric) M12	C	50
FF54650	Nylon Insert Locking Nuts (Unf) 1/2"		50
FF54830K	Nylon Insert Locking Nuts (Metric) M6	D	50
FF54840K	Nylon Insert Locking Nuts (Metric) M8	D	50
FF54850K	Nylon Insert Locking Nuts (Metric) M10	D	50
FF54860	Nylon Insert Locking Nuts (Metric) M12	D	50
FF54880	Nylon Insert Locking Nuts (Metric) M16	D	50
FF55220	Number Plate Nylon Nuts and Bolts (Pairs) Black	E	50
FF55230	Number Plate Flip Top Screws, Cups, Domes (Sets) White	E	50
FF55240	Number Plate Flip Top Screws, Cups, Domes (Sets) Yellow	E	50
FF55250	Number Plate Flip Top Screws, Cups, Domes (Sets) Black	E	50
FF55334K	Form A Flat Washers (Metric) M6	F	50
FF55335K	Form A Flat Washers (Metric) M8	F	50
FF55336K	Form A Flat Washers (Metric) M10	F	50
FF55337K	Form A Flat Washers (Metric) M12	F	50
FF55350	Form C Flat Washers (Metric) M6	F	50
FF55360	Form C Flat Washers (Metric) M8	F	50
FF55370	Form C Flat Washers (Metric) M10	F	50
FF55380	Form C Flat Washers (Metric) M12	F	50
FF55390	Form C Flat Washers (Metric) M16	F	50
FF55700K	Table 4 Flat Washers (Imperial) 1/2"		50
FF55940K	Spring Washers (Metric) M8		50
FF56010K	Repair Washers (Imperial) 1/4" x 1"	G	50
FF56030K	Repair Washers (Imperial) 5/16" x 1"	G	50
FF56040K	Repair Washers (Imperial) 5/16" x 1 1/2"	G	50
FF56060K	Repair Washers (Imperial) 3/8" x 1.1/2"		50
FF56101	Sump Plug Washer Ford	H	50

A



B



C



D



E



F



G



H



FASTENERS (CONTINUED)

PART NO.	DESCRIPTION		QTY
FF56580	Avdel Avex Alloy Rivits L/Flan 3/16" x 3/4"	I	50
FF56590	Avdel Avex Alloy Rivits L/Flan 3/16" x 1"	I	50
FF56760K	Acme Screws Hex Head 14 x 3/4"	J	50
FF58730	Self Tappers Blk PZD Flange 10 x 3/4"		50
FF59910	Threaded Rod M8 x 300mm		10
FF59920	Threaded Rod M10 x 300mm		10
FH70950	Linch Pins 1/4"	K	10
FZ60150	HT Through Bolt (Metric) M8 x 75mm	L	
FZ60160	HT Through Bolt (Metric) M10 x 100mm	L	
FZ74000	BZP Steel Chain M6 x 24mm 20m Reel	M	



MARKING CRAYONS

PART NO.	DESCRIPTION		QTY
203000	Yellow Wax Crayons	A	10
203020	White Wax Crayons	A	10
203040	Red Wax Crayons	A	10
203060	Green Wax Crayons	A	10
203080	Blue Wax Crayons	A	10
203090	Black Wax Crayons	A	10
203100	White Paint Sticks	B	12
203120	Yellow Paint Sticks	B	12



TYRE BUFFING ACCESSORIES

PART NO.	DESCRIPTION		SIZE	QTY
013000	Tyre Router	K	3mm	1
013020	Tyre Router	L	6mm	1
013034	Tyre Router		10mm	1
013040	Carbide Cutter Diamond Cut		3mm	1
013060	Carbide Cutter Diamond Cut		6mm	1
013080	Carbide Cutter Diamond Cut		8mm	1
013100	Carbide Cutter Diamond Cut		10mm	1
013120	Carbide Cutter Diamond Cut		13mm	1
219000	Flap Wheel	C	40mm x 20mm 80 Grit	1
219020	Flap Wheel	C	60mm x 30mm 80 Grit	1
219024	Flap Wheel	C	80mm x 15mm 80 Grit	1
219040	Buffing Disc	D	2.5"/64mm Diameter	1
219060	Arbour	E	6mm Shank	1
219080	Rotary Wire Brush	F	6mm Shank	1
219100	Twist Knot Rotary Wire Brush	G	6mm Shank	1
219102	Twist Knot Rotary Brush Premium		6mm	1

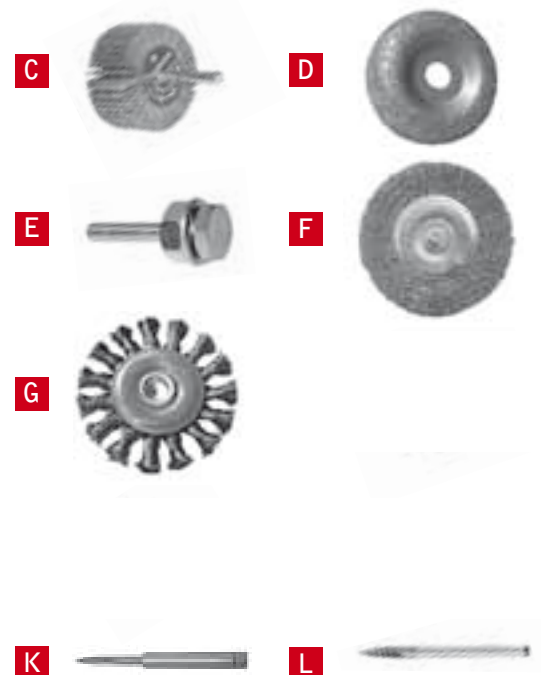

TYRE BUFFING ACCESSORIES (CONTINUED)

PART NO.	DESCRIPTION	SIZE	QTY
219120	Oxide Stone	M 25mm Diameter	1
219140	Oxide Stone	M 50mm Diameter	1
219160	Spherical Rasp "Golf Ball"	N N/A	1
219320	Flared Contour Wheel	O 64mm	1
219330	Poly Plug For 219320	N/A	
219400	Flexistrip Glass Fibre Backed Buffing Disc Open Woven	P 115mm	1
219500	Stripe Off Disc For Removing Decals/Adhesive	Q 6mm Shank	1
219510	Stripe Off Disc Threaded Shank For Removing Decals/Adhesive	R	1

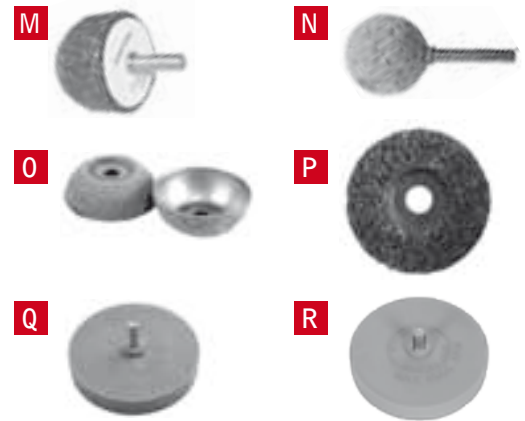

ABRASIVES

PART NO.	DESCRIPTION	QTY
FX14275	PVC Insulation Tape 19mm x 20m Black	Q 10
FD30352	Salika Emery Tape 1" x 50m 80 G	R 1
FD30372	Salika Emery Sheets 80 G	R 25
FD30374	Salika Emery Sheets 40 G	R 25
218307	Grinding Disc 75 x 1.6mm	S 1
218308	Grinding Disc 100 x 1.6mm	S 1
FD33020	Cut Off Discs 115 x 1.6 x 22mm	T 10
FD30760	Metal Cutting Disc DPC 115 x 3 x 22mm	T 10
FD31160	Double Sided Foam Tape Black 25mm x 10m	U 2
FD31170	Double Sided Foam Tape Black 50mm x 10m	U 1
FD31100	Clipper Mask Tape 24mm x 50m	V 6
FD31110	Clipper Mask Tape 48mm x 50m	V 3

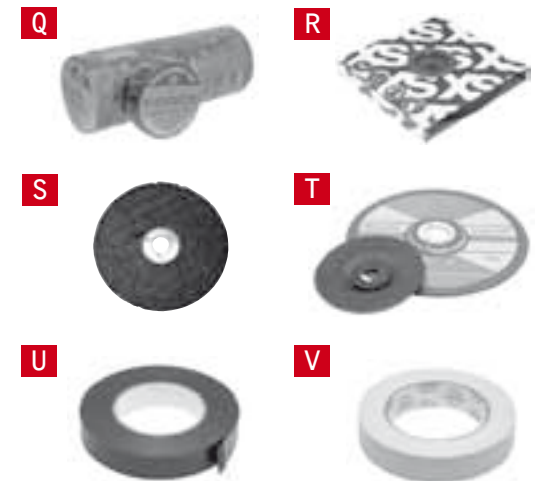

LEVERS, SPIDERS AND BRACES

TYRE LEVERS

PART NO.	DESCRIPTION	SIZE	QTY
220000	Vanadium	A 8"/200mm	1
220020	Vanadium	A 12"/300mm	1
220022	Vanadium Premium	A 12"/300mm	1
220030	Vanadium	A 16"/400mm	1
220032	Vanadium Premium	A 16"/400mm	1
220050	Vanadium	A 20"/500mm	1
220052	Vanadium Premium	A 20"/500mm	1
220040	Vanadium	A 24"/600mm	1
220042	Vanadium Premium	A 24"/600mm	1
220060	Tubeless Tyre TTL1	B 20mm Dia. x 34"/870mm	1
220070	Tubeless Tyre TTL2 2	C 2mm Dia. x 30"/770mm	1
220080	Tubeless Tyre TTL3	D 22mm Dia. x 30"/770mm	1
220100	Tubeless Tyre TTL4	E 25 x 12mm Dia. 34"/870mm	1
220120	Tubeless Tyre TTL5	F 22mm Dia. x 37.5"/970mm	1



TYRE LEVERS (CONTINUED)

PART NO.	DESCRIPTION	SIZE	QTY
220140	Tubeless Tyre TTL6	G 22mm Dia. x 39"/990mm	1
220160	Flat Cranked TL50	H 23"/600mm	1
220172	Tubeless Tyre TL37/12	I 7/8" x 12"/305mm	1
220174	Tubeless Tyre TL37/18	I 7/8" x 18"/450mm	1
220178	Tubeless Tyre TL38	J 25 x 12mm Dia. x 21"/530mm	1
220180	Round Hooked TL40	K 19.5"/520mm	1
220190	Round Hooked TL45	L 19"/510mm	1
220200	Flat Cranked TL55	M 35 x 10mm Dia.x 15.25"/290mm	1
220280	Motorcycle TL65	N 10mm Dia. x 7"/180mm	1
220210	Motorcycle TL70	N 15mm Dia. x 12"/305mm	1
220220	Rim Tool TL81A	O 19mm Dia. x 21.5"/550mm	1
220230	Spoon TL88	P 12.5mm Dia. x 9"/230mm	1
220240	Spoon TL90	P 12.5mm Dia. x 12"/305mm	1
220260	Spoon TL95	P 15.5mm Dia. x 20"/510mm	1
014060	Mount/Demount Bar	Q 22mm Dia. x 927mm	1
014120	Plastic Cover	R N/A	1
014140	Plastic Rim Protector	S N/A	1
504000	Earthmover Pry Bar TL100	T 22mm Dia. x 30"/770mm	1
504020	Earthmover Hook TL105	U 28mm Dia. x 38.5"/980mm	1

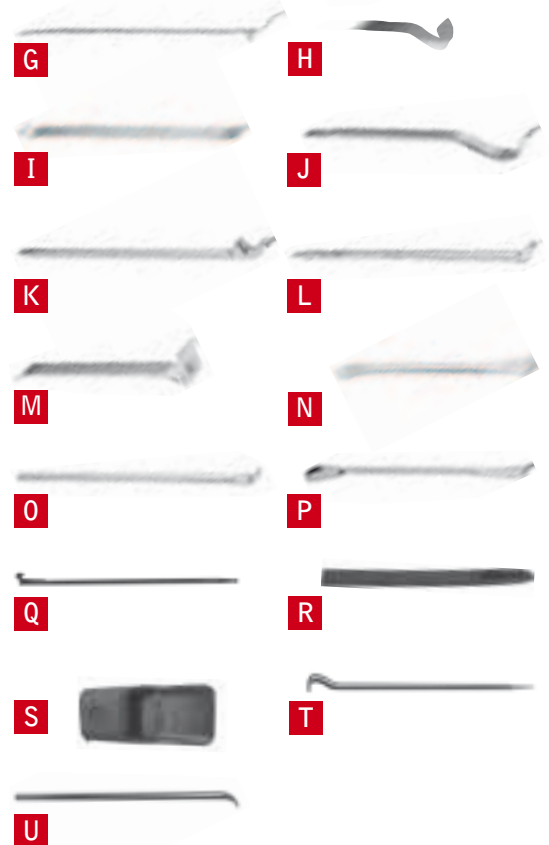

Michelin Type Tyre Levers Premium Lever

PART NO.	DESCRIPTION	SIZE(MM)	QTY
014000	HALTE Heavy Truck Tubeless on Drop Centre Rims	V 800	1
014020	FACE Tractors and Heavy Truck Tubeless	W 530	1
014040	FORCE Wide Section Drop Centre Truck Wheels	X 750	1
014200	MOTO Motorcycles	Y 380	1
014220	FUSIL Cars	Z 380	1
014240	FIACRE Tubed and Tubeless Heavy Trucks	AA 450	1
014260	FIFRE Flat Rim or Multi Piece Truck Wheels	BB 415	1
014280	HYOCA Super Single Wheels	CC 935	1
014300	HYUDE Super Single Wheels	DD 1000	1
014320	SAYAM Earthmovers	EE 950	1

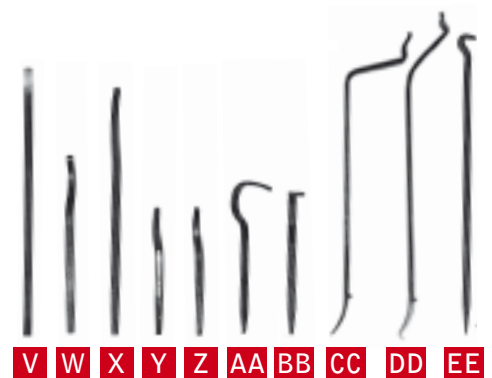

WHEEL SPIDERS

PART NO.	DESCRIPTION	SIZE	QTY
221005	Car Spider 4 Arm Standard	A 17/19/21/22	1
221010	Car Spider 4 Arm Vanadium	B 17/19/21/22	1
221020	Car Spider 4 Arm Vanadium	C 17/19/22/1/2"Sq. Dr.	1
221030	Car Spider 4 Arm VanadiumC	C 17/19/22/1/2"Sq. Dr.	1
221040	Car Spider 6 Arm Standard	D 16/17/19/21/22/24	1

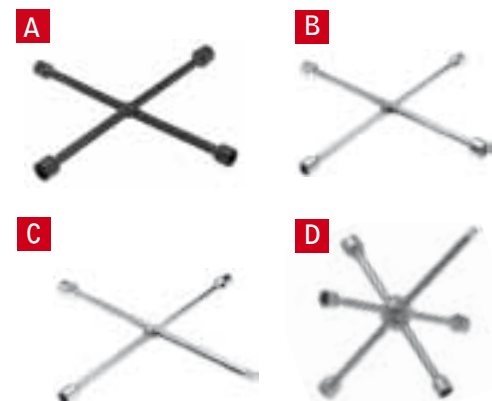

WHEEL BRACES - STANDARD

PART NO.	DESCRIPTION	SIZE	QTY
222012	Wheel Brace Standard Bi-Hex Taxi E	22mm	1
222016	Wheel Brace Standard Bi-Hex E	23mm	1
222020	Wheel Brace Standard Bi-Hex E	1/2" Whit.	1
222030	Wheel Brace Standard Bi-Hex E	15/16" AF	1
222040	Wheel Brace Standard Bi-Hex E	24mm	1
222046	Wheel Brace Standard Bi-Hex E	1" AF	1
222050	Wheel Brace Standard Bi-Hex E	26mm	1
222060	Wheel Brace Standard Bi-Hex E	27mm 1.1/16" AF	1
222066	Wheel Brace Standard Bi-Hex Taxi E	27mm	1
222080	Wheel Brace Standard Bi-Hex E	28mm 5/8" Whit.	1
222100	Wheel Brace Standard Bi-Hex E	1.1/8" AF	1
222110	Wheel Brace Standard Bi-Hex E	29mm	1
222120	Wheel Brace Standard Bi-Hex E	30mm 1.3/16" AF	1
222140	Wheel Brace Standard Bi-Hex E	32mm	1
222160	Wheel Brace Standard Bi-Hex E	33mm	1
222170	Wheel Brace Standard Bi-Hex E	3/4" Whit.	1
222180	Wheel Brace Standard Bi-Hex E	38mm 1.1/2" AF	1
222190	Wheel Brace Standard Bi-Hex E	41mm	1
222200	Brace Star Standard F		1
222220	Wheel Brace Extendable Socket G	17/19mm Socket	1
222300	Wheel Brace Standard Hex	19mm	1
222310	Wheel Brace Standard Hex	21mm	1
222330	Wheel Brace Standard Hex	23mm	1
222336	Wheel Brace Standard Hex	15/16" AF	1
222340	Wheel Brace Standard Hex	24mm	1
222346	Wheel Brace Standard Hex	1" AF	1
222350	Wheel Brace Standard Hex	26mm	1
222360	Wheel Brace Standard Hex	27mm	1
222380	Wheel Brace Standard Hex	5/8" Whit.	1
222400	Wheel Brace Standard Hex	1.1/8" AF	1
222420	Wheel Brace Standard Hex	30mm	1
222440	Wheel Brace Standard Hex	32mm	1
222460	Wheel Brace Standard Hex	33mm	1
222470	Wheel Brace Standard Hex	3/4" Whit.	1
222480	Wheel Brace Standard Hex	38mm	1
222500	1/2" Dr. Breaker Bar	18"	1
222520	1/2" Dr. Breaker Bar H	24"	1
222540	Replacement Knuckle I	1/2"	1
222560	3/4" Dr. Breaker Bar H	24"	1
222580	Replacement Knuckle I	3/4"	1

WHEEL BRACES - REINFORCED

PART NO.	DESCRIPTION	SIZE	QTY
223170	Wheel Brace Reinforced Bi-Hex B	3/4" Whit.	1
223180	Wheel Brace Reinforced Bi-Hex B	38mm 1.1/2" AF	1
223420	Wheel Brace Reinforced Hex C	30mm	1
223440	Wheel Brace Reinforced Hex D	32mm	1
223460	Wheel Brace Reinforced Hex	33mm	1
223470	Wheel Brace Reinforced Hex	3/4" Whit.	1
223200	Wheel Brace Hi-Torque C	1" Drive Socket End	1
223204	Wheel Brace Reinforced D	1" Drive Socket End	1

E



F



G



H



I



B



C



D



■ WHEEL BRACES - REINFORCED (CONTINUED)

PART NO.	DESCRIPTION	SIZE	QTY
223220	Brace Bar Hi-Torque E	N/A	
223000	Wheel Brace Reinforced Bi-Hex A	19mm 3/4" AF	1
223020	Wheel Brace Reinforced Bi-Hex A	1/2" Whit.	1
223040	Wheel Brace Reinforced Bi-Hex A	15/16" AF	1
223060	Wheel Brace Reinforced Bi-Hex A	27mm 1.1/16" AF	1
223080	Wheel Brace Reinforced Bi-Hex A	28mm 5/8" Whit.	1
223100	Wheel Brace Reinforced Bi-Hex A	1.1/8" AF	1
223120	Wheel Brace Reinforced Bi-Hex A	30mm 1.3/16" AF	1
223140	Wheel Brace Reinforced Bi-Hex A	32mm	1
223160	Wheel Brace Reinforced Bi-Hex A	33mm	1



SOCKETS, EXTENSIONS AND ADAPTORS

■ IMPACT SOCKETS 3/8" DRIVE DOUBLE DEPTH SOCKETS

PART NO.	DESCRIPTION	QTY
223830	3/8" Drive 8mm F	1
223832	3/8" Drive 9mm F	1
223834	3/8" Drive 10mm F	1
223836	3/8" Drive 11mm F	1
223838	3/8" Drive 12mm F	1
223840	3/8" Drive 13mm F	1
223842	3/8" Drive 14mm F	1
223846	3/8" Drive 16mm F	1
223848	3/8" Drive 17mm F	1
223850	3/8" Drive 18mm F	1
223852	3/8" Drive 19mm F	1



■ IMPACT SOCKETS 1/2" SQUARE DRIVE STANDARD

PART NO.	DESCRIPTION	QTY
224000	1/2" Drive x 17mm A	1
224020	1/2" Drive x 11/16" AF A	1
224030	1/2" Drive x 18mm A	1
224040	1/2" Drive x 19mm 3/4" AF A	1
224050	1/2" Drive x 20mm A	1
224060	1/2" Drive x 13/16" AF A	1
224080	1/2" Drive x 21mm 7/16" Whit. A	1
224100	1/2" Drive x 22mm A	1
224110	1/2" Drive x 23mm A	1
224120	1/2" Drive x 15/16" AF A	1
224140	1/2" Drive x 24mm A	1
224142	1/2" Drive x 25mm A	1
224150	1/2" Drive x 26mm A	1
224160	1/2" Drive x 27mm 1.1/16" AF A	1
224162	1/2" Drive x 28mm A	1
224166	1/2" Drive x 29mm A	1



■ IMPACT SOCKETS 1/2" SQUARE DRIVE STANDARD (CONTINUED)

224170	1/2" Drive x 30mm	A	1
224180	1/2" Drive x 32mm	A	1
224200	1/2" Drive x 33mm	A	1

A



■ IMPACT SOCKETS 1/2" SQUARE DRIVE DOUBLE DEPTH

PART NO.	DESCRIPTION		QTY
224980	1/2" Drive x 9mm	B	1
224982	1/2" Drive x 10mm	B	1
224983	1/2" Drive x 11mm	B	1
224986	1/2" Drive x 12mm	B	1
224988	1/2" Drive x 13mm	B	1
224990	1/2" Drive x 14mm	B	1
224992	1/2" Drive x 15mm	B	1
224996	1/2" Drive x 16mm	B	1
225000	1/2" Drive x 11/16" AF	B	1
225020	1/2" Drive x 17mm	B	1
225030	1/2" Drive x 18mm	B	1
225040	1/2" Drive x 19mm 3/4" AF	B	1
225050	1/2" Drive x 20mm	B	1
225060	1/2" Drive x 21mm 7/16" AF	B	1
225064	1/2" Drive x 22mm	B	1
225066	1/2" Drive x 23mm	B	1
225068	1/2" Drive x 15/16" AF	B	1
225070	1/2" Drive x 24mm	B	1
225072	1/2" Drive x 25mm	B	1
225078	1/2" Drive x 26mm	B	1
225080	1/2" Drive x 27mm 1.1/16" AF	B	1
225090	1/2" Drive x 28mm	B	1
225094	1/2" Drive x 29mm	B	1
225100	1/2" Drive x 30mm 1.3/16" AF	B	1
225120	1/2" Drive x 32mm	B	1
225140	1/2" Drive x 33mm 3/4" Whit.	B	1
225150	1/2" Drive x 34mm	B	1
225160	1/2" Drive x 36mm	B	1
225180	1/2" Drive x 38mm	B	1
225220	1/2" Drive x 41mm	B	1

B



■ IMPACT SOCKET SET 1/2" SQUARE DRIVE DOUBLE DEPTH

PART NO.	DESCRIPTION	QTY
226020	1/2" Dr. Impact Socket Set D/D mm	1

■ IMPACT SOCKETS 1/2" SQUARE DRIVE THIN WALL DOUBLE DEPTH

PART NO.	DESCRIPTION		QTY
225590	1/2" Drive x 15mm	B	1
225600	1/2" Drive x 17mm	B	1
225630	1/2" Drive x 18mm	B	1
225640	1/2" Drive x 19mm	B	1
225660	1/2" Drive x 21mm	B	1

B



■ IMPACT SOCKETS 1/2" SQUARE DRIVE INSULATED DOUBLE DEPTH

PART NO.	DESCRIPTION		QTY
225810	1/2" Drive x 17mm	C	1
225812	1/2" Drive x 19mm	D	1
225814	1/2" Drive x 21mm	E	1
225816	1/2" Drive x 22mm		1



■ IMPACT SOCKET SET 1/2" SQUARE DRIVE INSULATED DOUBLE DEPTH

PART NO.	DESCRIPTION		QTY
226100	1/2" Drive 3 Piece (17, 19, 21mm)	F	1
226102	1/2" Drive 4 Piece (17, 19, 21, 27mm)		1



■ IMPACT SOCKETS 3/4" SQUARE DRIVE DOUBLE DEPTH

PART NO.	DESCRIPTION		QTY
226500	226500 3/4" Drive x 19mm 3/4" AF	G	1
226504	226504 3/4" Drive x 21mm	G	1
226506	226506 3/4" Drive x 22mm	G	1
226520	226520 3/4" Drive x 24mm G 1	G	1
226540	226540 3/4" Drive x 27mm 1.1/16" AF	G	1
226550	226550 3/4" Drive x 28mm	G	1
226554	226554 3/4" Drive x 29mm	G	1
226560	226560 3/4" Drive x 30mm 1.3/16" AF	G	1
226580	226580 3/4" Drive x 32mm G 1	G	1
226600	226600 3/4" Drive x 33mm 3/4" Whit.	G	1
226610	226610 3/4" Drive x 36mm	G	1
226620	226620 3/4" Drive x 38mm	G	1
226640	226640 3/4" Drive x 41mm	G	1



■ IMPACT SOCKET SET 3/4" SQUARE DRIVE DOUBLE DEPTH

PART NO.	DESCRIPTION		QTY
229100	3/4" Drive 8 Piece (26,27,29,30,32,35,36,38mm)	A	1



■ IMPACT SOCKETS 1" SQUARE DRIVE DOUBLE DEPTH

PART NO.	DESCRIPTION		QTY
227000	1" Drive x 19mm 3/4" AF	B	1
227010	1" Drive x 21mm	B	1
227020	1" Drive x 15/16" AF	B	1
227040	1" Drive x 24mm	B	1
227050	1" Drive x 1" AF	B	1
227060	1" Drive x 26mm	B	1



M2064 1/2" Dr. Ultra Compact Air Impact Wrench
1000Ft/Lb - 1256Nm

- Ideal for accessing tight spaces
- Ultra-compact with impressive power to weight ratio
- Twin hammer mechanism
- 1000ft/lbs of maximum torque with 9,000 rpm no load speed
- Max pressure is 90psi / 6.3 bar
- One hand operation trigger
- 3 speed settings in both forward and reverse
- Setting switch is at rear of handle
- Handle exhaust
- Durable composite housing
- Weighs 1.8kg
- Vibration: 2.8m/s²
- 2 Year Warranty

M3306 6pc 1/2" Dr. Wheel Nut Impact Socket Set
Includes the ms17 socket to fit the newer Mercedes-Benz models

- 1/2" square drive wheel nut socket set for alloy wheels
- Reinforced steel ring to prevent splitting
- Made from Chrome Vanadium and Chrome Molybdenum steel with a phosphate finish for added corrosion resistance
- Sleeve to protect alloy wheels
- Suitable for use with most impact tools
- Set includes:
 - MS17 (for Mercedes-Benz)
 - 15mm, 17mm and 19mm (common sizes)
 - 21mm and 22mm (for commercial vehicles)
- All 88mm in length

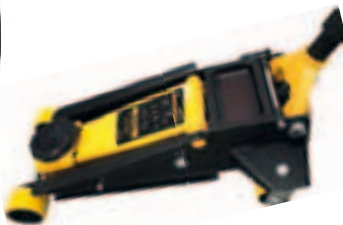

T3006 3.0T New Twin Piston Rapid Lift Service Jack

- Heavy duty hydraulic service jack
- 3.0 Ton capacity
- Lifting Range: 120mm – 460mm
- Universal Joint release Mechanism
- Soft rubber saddle pad to protect underside of the vehicle
- Foam protection handle for added protection to car bodywork
- Polyurethane (PU) wheels gives silent movement and also prevent damage to oil tight garage floor coverings
- Weighs 34.3kg

M2063 1/2" Dr Air Impact Wrench - 1/2" Dr. 922Ft/Lb – 1250Nm

The air impact wrench with bite – extreme torque, reliable technology

- Ideal for numerous vehicle maintenance applications, including tyre fitting
- One of the most swift, mighty and reliable 1/2" drive air impact wrenches on the market
- Twin hammer impact mechanism
- 922ft/lbs (1250Nm) maximum torque – full power in reverse
- 8,500rpm no load speed
- Single handed operation
- Three forward torque settings:
 - Low – 180 ft/lbs (245Nm)
 - Medium – 480 ft/lbs (650Nm)
 - High – 730 ft/lbs (990 Nm)
- Effortless setting switch is located at rear
- Durable and lightweight composite housing with titanium clutch case
- 360° swivel 1/4" air inlet to prevent air hose twisting
- Also features: full teasing trigger, friction ring socket retainer and handle exhaust
- 4.6cfm average air consumption
- 8.11m/2s vibration
- Weighs 2.1kg (4.6lbs)
- 2 Year Warranty

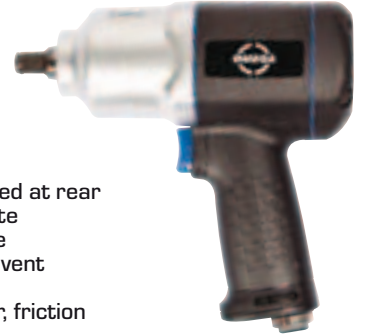

2903011 3.5T Hydraulic Service Jack

- Heavy duty hydraulic service jack
- 3.5 Ton capacity
- Lifting Range: 100mm – 485mm
- Universal Joint Mechanism
- Soft rubber saddle pad to protect underside of the vehicle
- Foam protection handle for added protection to car bodywork
- Polyurethane (PU) wheels gives silent movement and also prevent damage to oil tight garage floor coverings
- Weighs 41.0kg

2903101 3.0T Hydraulic Service Jack Ultra Low Entry

- Heavy duty hydraulic service jack
- 3.0 Ton capacity
- Lifting Range: 85mm – 500mm
- Universal Joint release Mechanism
- Soft rubber saddle pad to protect underside of the vehicle
- Foam protection handle for added protection to car bodywork
- Polyurethane (PU) wheels gives silent movement and also prevent damage to oil tight garage floor coverings
- Weighs 38.03kg

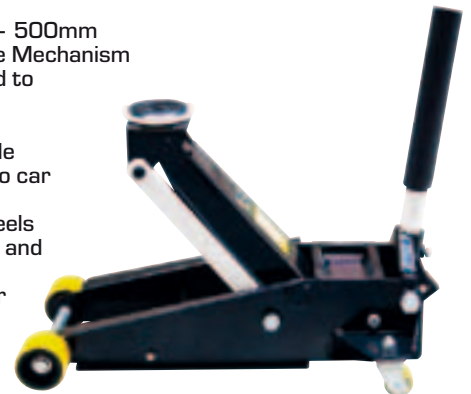

■ IMPACT SOCKETS 1" SQUARE DRIVE DOUBLE DEPTH (CONTINUED)

227080	1" Drive x 27mm 1.1/16" AF	B	1
227090	1" Drive x 28mm	B	1
227100	1" Drive x 1.1/8" AF	B	1
227110	1" Drive x 29mm	B	1
227120	1" Drive x 30mm 1.3/16" AF	B	1
227140	1" Drive x 32mm	B	1
227180	1" Drive x 33mm 3/4" Whit.	B	1
227184	1" Drive x 34mm	B	1
227190	1" Drive x 36mm	B	1
227200	1" Drive x 38mm 1.1/2" AF	B	1
227220	1" Drive x 41mm 1.5/8" AF	B	1
227230	1" Drive x 42mm	B	1
227240	1" Drive x 44mm	B	1
227280	1" Drive x 46mm 1.13/16" AF	B	1
227300	1" Drive x 1.7/8" AF	B	1

B



■ IMPACT SOCKETS 1" SQUARE DRIVE THIN WALL DOUBLE DEPTH

PART NO.	DESCRIPTION		QTY
228000	1" Drive x 24mm	C	1
228020	1" Drive x 27mm 1.1/16" AF	C	1
228040	1" Drive x 30mm 1.3/16" AF	C	1
228050	1" Drive x 32mm	C	1
228060	1" Drive x 33mm 3/4" Whit.	C	1
228070	1" Drive x 36mm	C	1
228080	1" Drive x 38mm 1.1/2" AF	C	1

C



■ IMPACT SOCKETS 1" SQUARE DRIVE BUDD/SQUARE DOUBLE DEPTH

PART NO.	DESCRIPTION		QTY
228500	1" Drive x 19mm 3/4" AF	D	1
228520	1" Drive x 13/16" AF	D	1
228540	1" Drive x 21mm 7/8" Whit.	D	1
228560	1" Drive x 24mm	D	1
228700	1" Drive x 21mm/41mm Hex Combination	D	1

D



■ IMPACT SOCKET 1" SQUARE DRIVE DOUBLE DEPTH

PART NO.	DESCRIPTION		QTY
229000	1" Drive 4 Piece (27,30,32,33mm)	A	1
229010	1" Drive 8 Piece (24,27,29,30,32,33,36,38mm)	B	1

A



B



■ EXTENSION BARS

PART NO.	DESCRIPTION	QTY
230000	1" Drive Impact Extension Bar 6"/152mm	1
230010	1" Drive Impact Extension Bar 8"/203mm	1
230020	1" Drive Impact Extension Bar 12"/305mm	C 1
230040	1" Drive Chrome Extension Bar 15.3/4"/400mm	1
230100	3/4" Drive Impact Extension Bar 6"/152mm	1
230200	1/2" Drive Impact Extension Bar 6"/152mm	1

■ IMPACT SOCKET DRIVE ADAPTORS

PART NO.	DESCRIPTION	QTY
231000	1" Sq. Drive Female x 3/4" Sq. Drive Male	D 1
231010	1" Sq. Drive Female x 1/2" Sq. Drive Male	1
231020	3/4" Sq. Drive Female x 1" Sq. Drive Male	1
231030	1/2" Sq. Drive Female x 1" Sq. Drive Male	1
231040	3/4" Sq. Drive Female x 1/2" Sq. Drive Male	1
231100	1/2" Sq. Drive Female x 3/4" Sq. Drive Male	1
231120	1/2" Sq. Drive Female x 3/8" Sq. Drive Male	1
231200	3/8" Sq. Drive Female x 1/2" Sq. Drive Male	1

■ LOCKING WHEEL NUT REMOVERS

PART NO.	DESCRIPTION	QTY
224900	1/2" Drive x 17mm	1
224902	1/2" Drive x 18.5mm	1
224904	1/2" Drive x 20mm	1
224906	1/2" Drive x 21.5mm	E 1
224908	1/2" Drive x 23mm	1
224910	1/2" Drive x 24.5mm	1
224912	1/2" Drive x 26mm	1

■ LOCKING WHEEL NUT REMOVER SET

PART NO.	DESCRIPTION	QTY
226200	1/2" Drive 7 Piece (17, 18.5, 20, 21.5, 23, 24.5, 26mm)	F 1
226210	Dynomec Locking Wheel Nut Remover	G 1
226220	Blade A Locking Wheel Nut Remover	H 1
226222	Blade B Locking Wheel Nut Remover	I 1
226224	Blade C Locking Wheel Nut Remover	J 1
226228	Locking Wheel Nut Spring Ring 4	K 1

TYRE REMOVAL TOOLS AND ACCESSORIES

■ TYRE LIFTING AND MOUNTING TOOLS

PART NO.	DESCRIPTION	SIZE	QTY
052000	Tyre Lifting Hook	2 Tonne	1
052060	Wheel Mounting Frame Mark 2	L N/A	1

C



D



E



F



G



H



I



J



K



L



■ AIR/OIL FOOT OPERATED PUMPS

- Compact portable design
- Heavy duty construction
- Foot pedal operated
- 700 bar working pressure

PART NO.	DESCRIPTION	SIZE	QTY
052120	Air/Oil Foot Pump	A	3.5ltr
052124	Air/Oil Foot Pump Steel Reservoir	B	4.7 Litres
052132	Reservoir Foot Pump	C	3.5ltr
052140	Hydraulic Pump Hand Operated	D	N/A
052400	Air/Oil Foot Pump		5ltr



■ BACK BEAD BREAKING RAM

This tool will efficiently break the back bead on a wide range of tractor, truck and grader tyres, whilst still on the vehicle. The bead breaker can be operated from a standard hand pump (052140) or with an air/oil foot operated pump (052120).

PART NO.	DESCRIPTION	SIZE	QTY
052220	Hydraulic Back Bead Breaking Ram	E	4"
052230	Bead Breaker Ram	EE	6"/152mm
052240	Hydraulic Back Bead Breaking Ram	F	4"



■ VIKING BEAD BREAKER

PART NO.	DESCRIPTION	QTY
052250	Viking Bead Breaker c/w 5 Magnetic Extensions	1



■ STANDARD BEAD BREAKING TOOL T1000

The 052300 tyre bead breaker is designed for 25" to 49" diameter earthmover wheels with 5 piece rims and pry bar slot. This unit is extremely light and portable. The bead breaker can be operated from a standard hand pump (052140) or with an air/oil foot operated pump (052120).

PART NO.	DESCRIPTION	QTY
052300	T1000T Bead Breaking Tool	1



■ LARGE BEAD BREAKING TOOL T1500

The 052310 tyre bead breaker is designed for 25" to 51" diameter earthmover wheels with 5 piece rim and pry bar slots. The unit is capable of approximately 50% more force than similar bead breaking tools enabling a far greater range of tyres to be removed with minimum effort. The bead breaker can be operated from a standard hand pump (052140) or with an air/oil foot operated pump (052120).

PART NO.	DESCRIPTION	QTY
052310	T1500 Bead Breaking Tool	1



■ BEAD BREAKING TOOL T1800

Designed for 25" to 51" diameter earthmover wheels with 5 piece rim and pry bar slots.

PART NO.	DESCRIPTION		QTY
052380	T1800 Bead Breaking Tool	A	1

■ GIANT BEAD BREAKING TOOL T2000

The 052320 tyre bead breaker is designed for 39" to 57" diameter earthmover wheels with 5 piece rims. The unit is capable of far more force than smaller bead breaker tools.

PART NO.	DESCRIPTION		QTY
052320	T2000 Head Assembly including Special Safety Adaptor Heavy Duty for Tyres 57" Upwards	B	1

■ TRUCK/TRACTOR/EARTHMOVER BEAD BREAKING TOOL

The 052340/052345 tractor/earthmover tools are designed to efficiently break the bead on a wide range of tractor, truck and grader wheels with 3 piece rims. The bead breaker can be operated from an air/oil foot operated pump (052120).

PART NO.	DESCRIPTION		QTY
052340	Tractor/Earthmover Bead Breaking Tool Low Cost	C	1
052345	Tractor/Earthmover Bead Breaking Tool Standard	D	1
052370	Pneumatic Gaither Tyre Bead Breaker	E	1
052560	Micro/Lem Bead Breaker Premium	F	1
052580	Mini/Lem Bead Breaker Premium	G	1
052600	Maxi Tractor/Earthmover Bead Breaker Standard	H	1
052620	Maxi/Lem Bead Breaker Premium	I	1

■ ALUMINIUM LIFTING JACK 55 TONNE

- This heavy duty jack is suitable for lifting most tractor, truck and grader vehicles when removing their wheels.
- Large base area
- Hardened steel top cap
- Built-in anti falldown valve
- Weight 14kg
- The unit can be operated from an air/oil foot operated pump (052120)

PART NO.	DESCRIPTION	SIZE	QTY
052420	Aluminium Lifting Jack	J 55 Tonne	1

■ BEAD BREAKING ACCESSORIES

PART NO.	DESCRIPTION		QTY
052100	Spade End Tool	K	1
052160	Hydraulic 8' Hose with Coupler	L	1
052260	Hook/Claw Fit Old T1000 1/2 Hole	O	1
052280	Hook/Claw Fit 052300/052310	P	1
052330	Hook Std Fit 052340	Q	1
052350	Hook Earthmover Fit 052340	R	1



CAR AND MOTORCYCLE VALVES

■ SNAP-IN TUBELESS VALVES MOTORCYCLE

PART NO.	REF NO.	DESCRIPTION	RIM HOLE DIAMETER (mm)	SIZE (mm)	QTY
234122	TR412	Tubeless Valve Chrome	11.3	33	1
234123	TR412	Chrome Sleeve Only	N/A	N/A	1
234180	TR412L	Go-Kart, Motorcycle and Industrial Vehicle Valve 90°	A	11.3	30
234200	N/A	Scooter Valve 90°	A	8.8	N/A

A



■ SNAP-IN TUBELESS VALVES CAR

PART NO.	REF NO.	DESCRIPTION	RIM HOLE DIAMETER (mm)	SIZE (mm)	QTY
M39P	TR414	Tubeless Valve Premium	B	11.3	49
M40P	TR418	Tubeless Valve Premium	C	11.3	61.5
234022	TR413	Tubeless Valve		43	100
234026	TR413	Tubeless Valve Premium		43	100
234040	TR414	Tubeless Valve OE	B	11.3	49
234044	TR414	Tubeless Valve Long OE		11.3	56.5
234060	TR415	Tubeless Valve		15.7	43
234080	TR418	Tubeless Valve OE	C	11.3	61.5
234090	TR423	Tubeless Valve		11.3	74
234095	TR425	Tubeless Valve		15.7	60.5
234100	TR438	Tubeless Valve TDX/Metro	D	8.8	59
234120	TR414	Tubeless Valve Chrome Long Sleeve	E	11.3	49
234121	TR414	Tubeless Valve Chrome Sleeve		11.3	49
234125	TR413	Valve Chrome Long Sleeve & Plastic Chrome Cap	F	43	100
234130	TR414	Chrome Long Sleeve Only		N/A	N/A
234131	TR414	Chrome Sleeve Only	G	N/A	N/A
234135	TR414	Tubeless Valve Chrome Long Sleeve		11.3	49
234140	TR418	Tubeless Valve Chrome Long Sleeve	H	11.3	61.5
234141	TR418	Tubeless Valve Chrome Sleeve		11.3	61.5
234150	TR418	Chrome Long Sleeve Only		N/A	N/A
234151	TR418	Chrome Sleeve Only		N/A	N/A
234155	TR418	Tubeless Valve Chrome Long Sleeve		11.3	61.5

B



C



D



E



F



G



H



■ SNAP-IN TUBELESS VALVES TRANSIT

PART NO.	REF NO.	DESCRIPTION	RIM HOLE DIAMETER (mm)	SIZE (mm)	QTY
234160	TR600HP	Transit Valve	I	11.3	44
234161	TR600XHP	Tubeless Transit Valve	J		44
234162	TR602	Transit Valve		11.3	63
234166	TR802HP	Tubeless Valve	K	15.7	66

I



J



K



METAL CLAMP-IN VALVES MOTORCYCLE

PART NO.	REF NO.	DESCRIPTION	RIM HOLE DIAMETER (mm)	SIZE (mm)	QTY
235100	TR430A	Clamp In Valve	K	8.3	44
235180	N/A	Clamp In Valve Alloy Ducati	L	8.3	30
235182	N/A	Alloy Motorcycle Valve	L	11.3	25

METAL CLAMP-IN VALVES CAR

PART NO.	REF NO.	DESCRIPTION	RIM HOLE DIAMETER (mm)	SIZE (mm)	QTY
235000	N/A	High Performance Tubeless Valve 8mm Nut	A	11.3	37
235010	N/A	High Performance Tubeless Valve 16mm Nut		11.3	37
235020	N/A	High Performance Tubeless Valve 16mm Nut	B	11.3	42
235030	N/A	High Performance Tubeless Valve 16mm Nut	C	11.3	42
235040	TR416S	High Performance Tubeless Valve	D	11.3	36.5
235050	TR416	High Performance Tubeless Valve	E	15.7	36.5
235060	N/A	Mercedes Type Tubeless Valve	E	11.3	45
235070	R-1510	Van/Light Truck Clamp In Valves		11.3	30
235072	521MS	Clamp In Valve		11.3	30
235120	N/A	High Performance Tubeless Valve	F	8.3	39
235130	N/A	Metal Valve	G	8.3	39
235160	N/A	Clamp In Valve Japanese Alloy	H	6	39.5
235170	N/A	Clamp In Valve Japanese Alloy 900		6	71
235200	N/A	Invisible Valve Kit - 4 Valves	I	11.3	25
235220	N/A	Inner Mounted Tubeless Valves "Enkei"	H	11.3	33
235240	N/A	Inner Mounted Tubeless Valves "Enkei"		11.3	43
235260	N/A	Inner Mounted Tubeless Valves "Enkei"	I	11.3	48
235280	N/A	Inner Mounted Tubeless Valves "Enkei"	J	11.3	53
235300	N/A	Inner Mounted Tubeless Valves "Enkei" 900	K	11.3	62
235320	N/A	Inner Mounted Tubeless Valves 900	L	11.3	77

METAL CLAMP-IN VALVES ALLOY RIMS CAR

PART NO.	REF NO.	DESCRIPTION	RIM HOLE DIAMETER (MM)	SIZE (MM)	QTY
235080	523MS	Clamp In Valve Alloy Type Grommet	0	11.3	36
235084	R1578	Alloy Tubeless Valve		9.7	30

TUBE VALVES CAR

PART NO.	REF NO.	DESCRIPTION	RIM HOLE DIAMETER (MM)	SIZE (MM)	QTY
239000	TR13	Car Tube Valve	Q	11.5	38
239020	TR15	Car Tube Valve	R	16	38

K



L



A



B



C



D



E



F



G



H



I



J



K



L



O



Q



R



TPMS VALVES, TOOLS AND ACCESSORIES

TPMS allow the pressure of each tyre to be continuously monitored and warns the vehicle driver of any problem via the dashboard. For the correct TPMS valve selection, please always quote the vehicle make, model and year of manufacture and refer to chart. Please always adhere to the correct procedures when changing tyres fitted with a TPMS system. Details available upon request.

TPMS TOOLS

PART NO.	DESCRIPTION		QTY
TPMSDOCK	ATEQ VT56 Docking Station and Printer	A	1
TPMSVT56	ATEQ VT56 with OBDII	B	1
TPMSVT36	ATEQ VT36	C	1
T72-20-657	ATEQ VT56 SE Unit	D	1
TPMSTOOLKIT	Tool Kit and Carry Case	E	1

OE MULTI SENSORS

PART NO.	DESCRIPTION		QTY
T72-20-085	Alligator Sens.It Clamp-In Sensor 434MHz	F	1
T72-20-820	VDO Redi Sensor 1	G	1
T72-20-845	Schrader Delta EZ Sensor 2.0 - EU 433Mhz	H	1
T72-20-887	HUF Intellisens 4030 Clamp-In Sensor	I	1

OE REPLACEMENT SENSORS

PART NO.	DESCRIPTION		QTY
T72-20-007	VDO Clamp-In TG1B Sensor	J	1
T72-20-015	Schrader Snap-In Rev 4 Sensor	K	1
T72-20-016	HUF Clamp-In Gen 1.2 Sensor	L	1
T72-20-024	VDO Clamp-In TG1C Sensor	M	1
T72-20-029	VDO Clamp-In TG1C Sensor	N	1
T72-20-032	Schrader Snap-In Rev 4 Sensor	O	1
T72-20-036	HUF Clamp-In Gen 2.4 Sensor		1
T72-20-046	HUF Clamp-In Gen 3.4 Sensor	P	1
T72-20-063	VDO Clamp-In TG1C Sensor	Q	1
T72-20-065	VDO Clamp-In TG1C Sensor	R	1
T72-20-091	VDO Clamp-In TG1C Sensor		1
T72-20-092	HUF Clamp-In Gen 3.4 Sensor	S	1
T72-20-093	Schrader High Speed Snap-In Sensor	T	1
T72-20-095	Pacific Clamp-In LFB1 Sensor	U	1
T72-20-096	Schrader High Speed Snap-In Sensor	V	1
T72-20-841	Schrader High Speed Snap-In Sensor	W	1
T72-20-843	Schrader Snap-In Faraday Sensor	X	1
T72-20-854	Schrader Clamp-In Gen Delta Sensor	Y	1



OE REPLACEMENT SENSORS (CONTINUED)

PART NO.	DESCRIPTION		QTY
T72-20-855	VDO Clamp In TG1C Sensor	A	1
T72-20-857	VDO Clamp-In TG1C Sensor	B	1



TECH SENSOR ACCESSORIES

PART NO.	DESCRIPTION		QTY
T72-20-424	Replacement Brass Valve For T-Pro Sensor	C	1
T72-20-436	Replacement Clamp-In Valves For T-Pro	D	1
T72-20-467	Snap In Valve for T-Pro Gen 2 10	E	1
T72-20-469	Replacement Black Clamp-In Valves for T-Pro	F	1

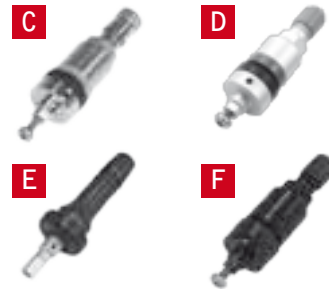

TECH SENSORS

PART NO.	DESCRIPTION		QTY
T72-20-384	T-Pro Hybrid Clamp-In Sensor	G	1



TECH SERVICE PARTS

PART NO.	DESCRIPTION		QTY
T72-20-501	Service Kits For Schrader Gen 2/3	H	1
T72-20-502	Service Kits For Schrader Gen 2/3	I	1
T72-20-503	Service Kits For Schrader Gen 2/3	J	1
T72-20-504	Service Kits For Schrader Gen 2/3	K	1
T72-20-505	Service Kits For VDO TG1B	L	1
T72-20-506	Service Kits For VDO TG1B	M	1
T72-20-507	Service Kits For Schrader Gen 2/3	N	1
T72-20-508	Service Kits For Schrader Gen Alpha	O	1
T72-20-510	Service Kits For Schrader Gen Alpha	P	1
T72-20-511	Service Kits For VDO TG1B	Q	1
T72-20-513	Service Kits For VDO TG1C	R	1
T72-20-514	Service Kits For VDO TG1C	S	1
T72-20-515	Service Kits For VDO TG1C	T	1
T72-20-520	Service Kits For HUF Gen1	U	1
T72-20-521	Service Kits For TECH Sensor	V	1
T72-20-522	Service Kits For VDO MB Sensor	W	1
T72-20-525	Service Kits For Pacific LFB1 / LFC1	X	1
T72-20-545 Starter Kit 1 contains:	T72-20-503, T72-20-504, T72-20-505, T72-20-506, T72-20-507, T72-20-508, T72-20-511, T72-20-513, T72-20-525, T72-20-401, T72-20-441, T72-20-442, T72-20-443, T72-20-448, T72-20-453, T72-20-512, T72-20-516	Y	1
T72-20-546 Starter Kit 2 contains:	T72-20-436, T72-20-437, T72-20-438, T72-20-439, T72-20-440, T72-20-449, T72-20-454, T72-20-455, T72-20-456, T72-20-457, T72-20-458, T72-20-459, T72-20-460, T72-20-461, T72-20-515, T72-20-520	Z	1



TECH VALVES

PART NO.	DESCRIPTION		QTY
T72-20-401	Replacement Valves For Schrader Gen 4 Sensor 10	A	1
T72-20-437	Replacement Valves For Snap-In TRW Sensor	B	1
T72-20-438	Replacement Valves For Schrader Gen Gamma	C	1
T72-20-440	Replacement Valves For VDO TG1D	D	1
T72-20-442	Replacement Valves For VDO TG1C Sensor	E	1
T72-20-443	Replacement Valves For Sch GenAlpha Sensor	F	1
T72-20-444	Replacement MB Service Valves	G	1
T72-20-445	Replacement Valves For VDO MB	H	1
T72-20-447	Replacement Valves For Huf Sensor - 51mm	I	1
T72-20-448	Replacement Valves For Schrader Gen 4 Sensor	J	1
T72-20-449	Replacement Valves For Schrader EZ Sensor HS	K	1
T72-20-453	Replacement Valves For VDO TG1B Sensor	L	1
T72-20-454	Replacement Valves For HUF Gen 2 - 43mm	M	1
T72-20-459	Valves for TRW Version 3	N	1
T72-20-460	Replacement Valves For Schrader EZ Sensor	O	1
T72-20-462	Replacement Snap-In Valves For EZ Sensor 10	P	1
T72-20-465	Replacement Clamp-In Gen 2 Valves HUF 49mm	Q	1

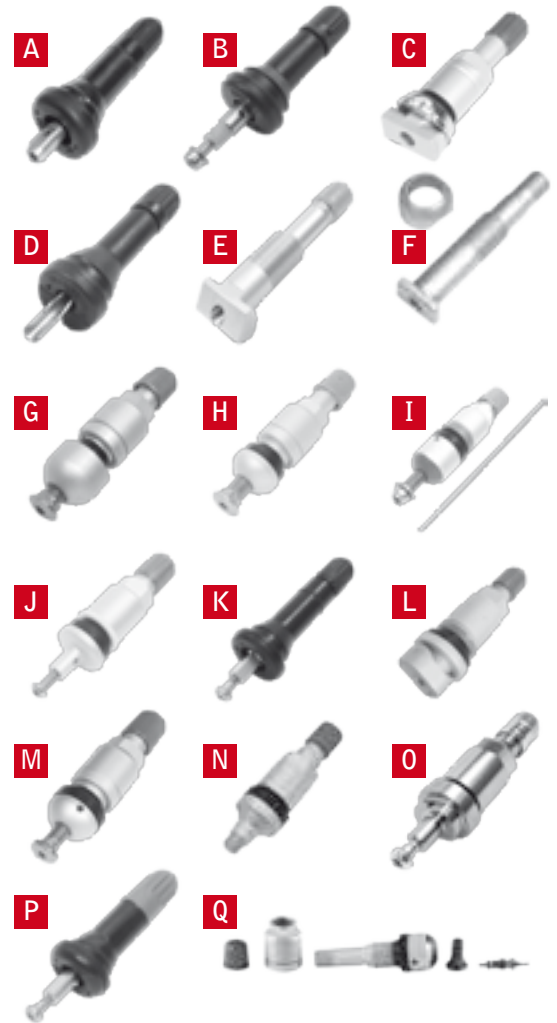

TRUCK VALVES

CLAMP-IN TUBELESS VALVES TRUCK/BUS

PART NO.	REF NO.	DESCRIPTION	RIM HOLE DIAMETER (mm)	SIZE (mm)	QTY
236000	TR570	Truck Valve	15.7	84	1
236020	TR570C	Truck Valve 900 Bend	A	15.7	52
236030	TR501	Truck Valve	15.7	42	1
236035	TR573	Truck Valve	15.7	114	1
236036	TR571	Truck Valve	15.7	89	1
236040	TR575	Truck Valve	B	15.7	33
236050	TR573C	T/L Valve Long 90 Degree	C	126	1
236060	V3-20-1	Truck Valve	D	9.7	41
236062		T/L Valve Long	E	36	1
236064	V3-20-1	Truck Valve Nickel	9.7	41	1
236070	N/A	Truck Valve Speedline Alloy	F	9.7	33
236074	N/A	Truck Valve	9.7	70	1
236080	90MS9.7	Truck Valve	G	9.7	91
236100	114MS9.7	Truck Valve	9.7	114	1
236110	V3-20-2	Truck Valve 170 Bend	9.7	91	1
236120	V3-20-4	Truck Valve 270 Bend	H	9.7	91



■ CLAMP-IN TUBELESS VALVES TRUCK/BUS CONTINUED

PART NO.	REF NO.	DESCRIPTION	RIM HOLE	SIZE (mm)	QTY
236128	V3-20-7	Truck Valve 270 Bend		9.7 80	1
236129	R1485	Truck Valve 270 Bend		9.7 85	1
236130	V3-20-5	Truck Valve 270 Bend		9.7 65	1
236132	N/A	Truck Valve Nickel 270 Bend		9.7 56	1
236140	114MS9.7-27	Truck Valve 270 Bend		9.7 110	1
236160	V3-12-1	Truck Valve For Drop Centre Rims	I	15.7 40	1
236170	N/A	Twin Turret Valve	J	15.7 30	1
236180	V3-12-2	Truck Valve For Drop Centre Rims	K	15.7 95	1
236190	N/A	Truck Valve For Drop Centre Rims		15.7 30	1
236199	V3-14-1	Truck Valve For Drop Centre Rims		15.7 75	1
236200	N/A	Truck Valve For Drop Centre Rims	L	15.7 95	1
236204	1184-2	Turret Truck T/T Valve V3.14.3			
236210	F2112	Scania Truck Valve	M	15.7 36	1
236220	70MS9.7-60	Alcoa Aluminium Truck Valve		9.7 70	1
236240	58MS9.7-45	Safety Hump Truck Valve	N	9.7 58	1
236242	58MS9.7-45	Safety Hump Truck Valve		9.7 58	1
236250	N/A	Truck Valve Nickel 600 Bend		9.7 92	1
236260	TR511	Tubeless Drop Centre Aluminium		15.7 108	1
236300	TR542	Alcoa Aluminium Truck Valve	O	9.7 32	1
236310	40MS-00N	T/L Valve Alcoa	Q	40	1
236314	54MS-00N	T/L Valve Alcoa	R	54	1
236320	TR543	Alcoa Aluminium Truck Valve		9.7 59	1
236324	TR543D	T/L Valve Alcoa 60 Deg Bend	S	60	
236340	TR544	Alcoa Aluminium Truck Valve	P	9.7 73	1
236360	TR545	Alcoa Aluminium Truck Valve		9.7 89	1
236380	TR546	Alcoa Aluminium Truck Valve		9.7 108	1
236400	TR547	Alcoa Aluminium Truck Valve		9.7 120	1
236460		Alcoa Aluminium Truck Valve		9.7 69	1
236500	N/A	Rim Blanking Spuds	T	15.7 20	1
236600	N/A	Guiding Flange Valve	U	N/A 108	1
236620	N/A	Guiding Flange Valve	U	N/A 83	1
236700	V3-15-1	Truck Valve For Drop Centre Rims		20.5 58.5	1
236702	V3-15-2	Truck Valve For Drop Centre Rims		20.5 55.5	1
236720	V3-16-1	Truck Valve For Drop Centre Rims		20.5 65	1



■ SCREW ON VALVES TRUCK - SCHRADER

PART NO.	REF NO.	DESCRIPTION	SIZE (MM)	QTY
237000	TR1175A	Schrader Valve Single Bend VG12 Thread	A 95	1
237020	TR1179A	Schrader Valve Single Bend VG12 Thread	A 140	1

A



■ SCREW ON VALVES TRUCK - MICHELIN (UNIVERSAL)

PART NO.	REF NO.	DESCRIPTION	SIZE (MM)	QTY
238000	V3-02-5	Michelin Valve Single Bend VG8 Thread	B 65	1
238010	V3-02-2	Michelin Valve Single Bend VG8 Thread	43	1
238020	V3-02-8	Michelin Valve Single Bend VG8 Thread	85	1
238030	V3-02-9	Michelin Valve Single Bend VG8 Thread	99.5	1
238040	V3-02-10	Michelin Valve Single Bend VG8 Thread	115	1
238060	V3-02-14	Michelin Valve Single Bend VG8 Thread	140	1

B



■ RUBBER BASED VALVES TRUCK/TRACTOR

PART NO.	REF NO.	DESCRIPTION	SIZE (MM)	QTY
239040	TR218	Rubber Based Valve Air/Water Tractor	C 47	1
239060	N/A	Rubber Based Valve Truck VG8	D N/A	1
239080	N/A	Rubber Based Valve Truck VG12	N/A	1
244040	N/A	Core Housing Rim Nuts For Tractor Valves - Plastic	E N/A	25
244050	N/A	Core Housing Rim Nuts For Tractor Valves - Brass	F N/A	25
239200	N/A	Threaded Valve Adaptor	N/A	1

C



D



E



F



■ VALVES FOR INDUSTRIAL APPLICATIONS

PART NO.	DESCRIPTION	SIZE (MM)	QTY
258010	Tank Valve 1/8" BSP	G 33.3	1
258020	Tank Valve 1/8" BSP	G 21.7	1
258030	Tank Valve 1/8" BSP	G 25	1
258200	No-Loss Connector	H N/A	1

G



H



I



TRACTOR AND EARTHMOVER VALVES

■ SNAP-IN VALVE AIR/WATER

PART NO.	REF NO.	DESCRIPTION	RIM HOLE DIAMETER (MM)	SIZE (MM)	QTY
401010	N/A	Air/Water Valve Snap-In	I 15.7	56	1

AIR LIQUID VALVES TRACTOR/ROAD GRADER AND VALVE CORE HOUSINGS

PART NO.	REF NO.	DESCRIPTION	RIM HOLE DIAMETER (MM)	SIZE (MM)	QTY
401000	TR618	Tubeless Tractor/Grader Valve	A	15.7	51
401020	TR623A	Tubeless Tractor/Grader Valve 65° Bend		15.7	95
401030	TR621A	Tubeless Tractor/Grader Valve 115° Bend		15.7	64
401040	TR622A	Tubeless Tractor/Grader Valve 90° Bend	B	15.7	114
233080	TRCH3	Core Housing Air/Water New	C	N/A	36
233100	TRCH1	Core Housing Air/Water Old	D	N/A	40

LARGE BORE SWIVEL STEM VALVES

PART NO.	REF NO.	DESCRIPTION	SIZE (MM)	QTY
301000	TRJ670	Straight Swivel Valve	E	41
301020	TRJ671	Straight Swivel Valve	F	40.5
301040	TRJ653	Single Bend Valve 80°	G	47
301060	TRJ655	Single Bend Valve 74°		79
301080	TRJ650	Single Bend Valve 80°	H	70
301090	TRJ4000-2.50	Single Bend Valve 80°		64
301100	TRJ4000-4.25	Single Bend Valve 90°		108
301120	TRJ4000-4.50	Single Bend Valve 90°		114
301140	TRJ651	Single Bend Valve 90°		119
301160	TRJ652	Single Bend Valve 86°		140
301180	TRJ4000-6	Single Bend Valve 90°	I	152
301200	TRJ648	Single Bend Valve 90°	J	194
301220	TRJ4000-8	Single Bend Valve 90°		203
301240	TRJ4000-9	Single Bend Valve 90°	K	229
301260	TRJ4000-11.50	Single Bend Valve 90°	L	292
301280	TRJ4000-17	Single Bend Valve 90°		432
301300	TRJ4000-19.50	Single Bend Valve 90°	M	495
301320	TRJ4000-24	Single Bend Valve 90°		610
301340	TRJ4000-26.50	Single Bend Valve 90°		667
301360	TRJ4000-28	Single Bend Valve 90°		705
301380	TRJ4000-30.50	Single Bend Valve 90°		774
301400	TRJ4000-31	Single Bend Valve 90°		787
301420	TRJ4000-32	Single Bend Valve 90°		813
301440	TRJ4000-33.50	Single Bend Valve 90°		851
301460	TRJ4000-45	Single Bend Valve 90°		1143
301500	N/A	CAT 769/BOW 5 Bend Valve Inner Rear		N/A
301520	N/A	CAT 769 Single Bend Valve Front	N	76
301540	N/A	CAT 769 5 Bend Valve Inner Rear	O	N/A
301560	N/A	CAT 773/BOW 5 Bend Valve Inner Rear		N/A
301580	N/A	CAT 773 Single Bend Valve 60° Front	N	83
301600	N/A	CAT 773 5 Bend Valve Inner Rear	P	N/A
301620	N/A	CAT 777 4 Bend NT Valve Inner Rear		N/A
301640	N/A	CAT 777B 4 Bend NT Valve Inner Rear		N/A

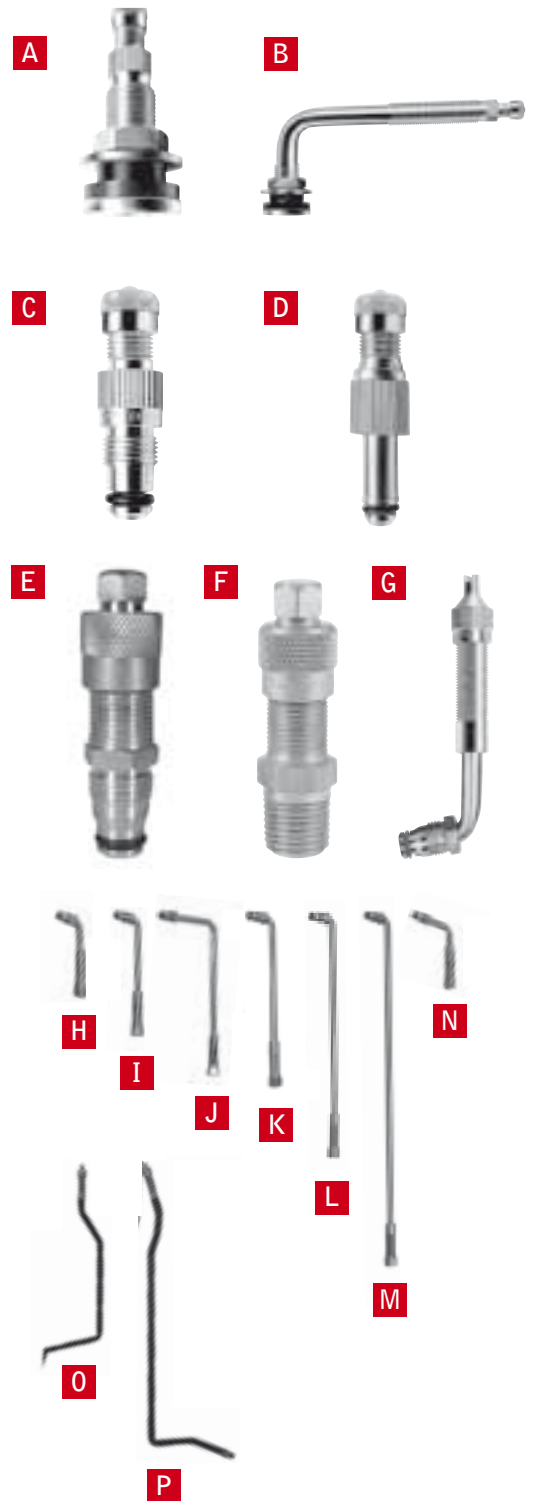

301660	N/A	CAT 777 5 Bend Valve Inner Rear	R	N/A	1
301680	N/A	CAT 777 Single Bend Valve Front	S	N/A	1
301820	N/A	Terex R70 3 Bend Valve Front		N/A	1
301840	N/A	Terex R70 3 Bend Valve Inner Rear		N/A	1
301860	N/A	Terex R70 3 Bend Valve Outer Rear		N/A	1
301880	N/A	Terex 33-11 3 Bend Valve Front	A	N/A	1
301900	N/A	Terex 33-11 3 Bend Valve Inner Rear	B	N/A	1
301920	N/A	Terex 33-11 3 Bend Valve Outer Rear		N/A	1
301940	N/A	Krest Carrier Single Bend Valve		N/A	1
301960	N/A	Michelin Pattern Single Bend Valve		N/A </td <td>1</td>	1
302000	N/A	CAT Loader Tyre Valve 980/988/992	C	45	1

■ LARGE BORE VALVES MISCELLANEOUS

PART NO.	REF NO.	DESCRIPTION	SIZE (MM)	QTY
402000	TRJ690	Turret Valve For Planetary Gear Wheels 90°	D 119	1
402002	TRJ691	Turret Valve For Planetary Gear Wheels 90°	84	1
402004	TRJ692	Turret Valve For Planetary Gear Wheels 90°	119	1
402020	TRJ1175C	Screw On Valve For Inner Tubeless	E 105	1

■ VALVE BASES AND TOOLS LARGE BORE

PART NO.	REF NO.	DESCRIPTION	SIZE (MM)	QTY
601120	TRJSP2	Tubeless Valves Spud For 13/16" Rim Hole	F N/A	1
601122		Tube Valve Spud for 20.5mm Hole	11	1
601124		Tube Valve Spud for 20.5mm Hole	G 16.5	1
601140	N/A	Spud Adaptor Converts Tubes For L/B Swivel Valves	H N/A	1
601180	N/A	Screw-In Spud Fits 631D Housing	I N/A	1
601200	N/A	Special T/L Valve Spuds Fits Without Tyre Dismount	N/A	1
601240	N/A	Fitting/Dismount Allen Key	N/A	1
601260	N/A	Tubeless Valve Blanking Spud	J N/A	1

■ SUPER LARGE BORE VALVES

PART NO.	REF NO.	DESCRIPTION	SIZE (INCH)	QTY
451040	N/A	R-525 Swivel Angle Connector 90° Bend	K N/A	1
451060	N/A	R-660 Swivel Angle Connector 60° Bend	N/A	1
451100	N/A	MR-700 Swivel Valve with Long Body*	N/A	1
451120	N/A	MR-800 Swivel Valve*	L N/A	1
451140	N/A	MR-890 Turret Valve*	M N/A	1
451160	N/A	N-1538B Turret Valve with 15° Bend used on Cat Applications	N 7.7/8	1
451180	N/A	N-1543A Turret Valve with 15° Bend used on Cat Applications	O 6.1/8	1
451200	N/A	N-1446 Turret Valve with 15° Bend	6	1
451220	N/A	MR-3000 Turret Valve*	P N/A	1
451260	N/A	MR-1950 Turret Valve Complete*	N/A	1

* Any length available to order.



VALVE BASES AND CORE HOUSINGS SUPER LARGE BORE

PART NO.	REF NO.	DESCRIPTION	SIZE (MM)	QTY
451000	TRJSP8	T81 Clamp In Spud	A	N/A 1
451020	N/A	K-665 Clamp In Spud*	B	N/A 1
451080	N/A	T82 Clamp In Spud*	C	N/A 1
301980	TRCH8	R520 Core Housing	D	47 1

* Fits without tyre dismount.



MOTORCYCLE, CAR AND LIGHT VAN EXTENSIONS

PLASTIC VALVE EXTENSION CAPS MOTORCYCLE/CAR

PART NO.	DESCRIPTION	SIZE(MM)	QTY
240180	Car Extension Plastic	E 19	1
240200	Car Extension Plastic	F 32	1
240210	Car Extension Plastic	38	1



PLASTIC EXTENSIONS TRUCK

PART NO.	DESCRIPTION	SIZE(MM)	QTY
240220	Truck Extension Plastic	G 51	1
240240	Truck Extension Plastic	G 71	1
240250	Truck Extension Plastic	G 85	1
240260	Truck Extension Plastic	G 95	1
240270	Truck Extension Plastic	G 98	1
240280	Truck Extension Plastic	G 115	1
240282	Truck Extension Plastic Black	H 115	1
240300	Truck Extension Plastic	G 125	1
240322	Truck Extension Plastic Black	H 150	1
240340	Truck Extension Plastic	G 170	1
240342	Truck Extension Plastic Black	H 170	1
240360	Truck Extension Plastic	G 180	1

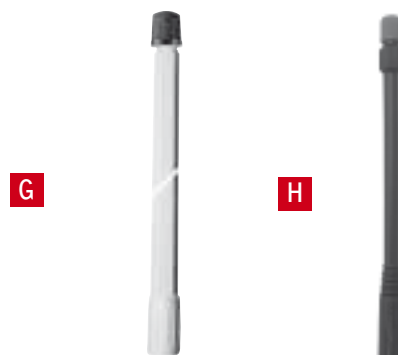

BRASS EXTENSIONS MOTORCYCLE

PART NO.	DESCRIPTION	SIZE(MM)	QTY
240160	Motorcycle Extension 90° Bend	I 32	1
240162	Motorcycle Extension 45° Bend	32	1



METAL VALVE EXTENSION CAPS CAR/TRUCK

PART NO.	DESCRIPTION	SIZE(MM)	QTY
240000	Car Extension Chrome	J 19	1
240020	Car Extension Chrome	K 32	1
240030	Double Check Caps	L 32	1



■ BRASS EXTENSIONS TRUCK

PART NO.	DESCRIPTION	SIZE(MM)	QTY
240040	Truck Extension Brass	A 36	1
240060	Truck Extension Brass	A 60	1
240080	Truck Extension Brass	A 84	1
240094	Truck Extension Brass	A 100	1
240100	Truck Extension Brass	A 115	1
240120	Truck Extension Brass	A 129	1
240139	Truck Extension Nickel	141	1
240140	Truck Extension Brass	A 142	1
240144	Truck Extension Nickel	156	1
240150	Truck Extension Brass	A 177.5	1

A



■ RIGID BRASS EXTENSIONS LARGE BORE

PART NO.	DESCRIPTION	SIZE (mm)	QTY
501020	Rigid Extension	B 64	1
501040	Rigid Extension	B 102	1
501060	Rigid Extension	B 127	1
501070	Rigid Extension	B 159	1
501080	Rigid Extension	B 203	1
501100	Rigid Extension	B 279	1
501120	Rigid Extension	B 337	1

B



- Effective length provided
- Flexible extensions also available

■ FLEXIBLE VALVE EXTENSIONS TRUCK

PART NO.	DESCRIPTION	SIZE (mm)	QTY
241000	Truck Extension Rubber	C 105	1
241020	Truck Extension Rubber	C 120	1
241040	Truck Extension Rubber	C 140	1
241060	Truck Extension Rubber	C 180	1
241080	Truck Extension Rubber	C 210	1

C



■ FLEXIBLE VALVE EXTENSIONS TRUCK REINFORCED

Metal reinforced flexible valve extensions.

PART NO.	DESCRIPTION	LENGTH (mm)	QTY
241121	Michelin Steel Reinforced Flexible	D 105	1
241122	Michelin Steel Reinforced Flexible	D 125	1
241123	Michelin Steel Reinforced Flexible	D 140	1
241124	Michelin Steel Reinforced Flexible	A 160	1
241125	Michelin Steel Reinforced Flexible	A 180	1
241126	Michelin Steel Reinforced Flexible	A 210	1
241127	Michelin Steel Reinforced Flexible	A 270	1

D



■ FLEXIBLE VALVE EXTENSIONS TRUCK REINFORCED (CONTINUED)

Metal reinforced flexible valve extensions.

PART NO.	DESCRIPTION	LENGTH (mm)	QTY
241128	Michelin Steel Reinforced Flexible	A	340 1
241129	Michelin Steel Reinforced Flexible	A	370 1
241131	Michelin Steel Reinforced Flexible	A	490 1

A



■ FLEXIBLE VALVE EXTENSIONS TRUCK BENT

Metal reinforced flexible valve extensions.

PART NO.	DESCRIPTION	LENGTH (mm)	QTY
241133	Flexible Valve Extension Bent	B	140 1
241134	Flexible Valve Extension Bent	B	210 1
241135	Flexible Valve Extension Bent	B	280 1
241136	Flexible Valve Extension Bent	B	360 1
241137	Flexible Valve Extension Bent	B	460 1

B



■ FLEXIBLE VALVE EXTENSIONS TRUCK METAL BRAIDED REINFORCED

PART NO.	DESCRIPTION	LENGTH (mm)	QTY
241260	Truck Extension Reinforced	C	180 1
241280	Truck Extension Reinforced	C	210 1

C



■ EXTENSION MOUNTING BRACKETS

PART NO.	DESCRIPTION	LENGTH (mm)	QTY
242000	Mounting Bracket Single Morse	D	N/A 1
242020	Mounting Bracket Twin Farfe	E	N/A 1
242040	Mounting Bracket Single H/D Twin Morse	F	N/A 1
242060	Mounting Bracket TB Alloy Rim	N/A	1

D

E

F



■ FLEXIBLE VALVE EXTENSIONS LARGE BORE

PART NO.	DESCRIPTION	LENGTH (mm)	QTY
502610	Large Bore Flexible Valve Extension	D	310 1
502670	Large Bore Flexible Valve Extension	D	475 1
502740	Large Bore Flexible Valve Extension	D	690 1

D



VALVE CAPS

■ VALVE CAPS CAR/TRUCK

PART NO.	REF NO.	DESCRIPTION	QTY
232000	TRVC8	Valve Cap Plastic	E 100
232010	N/A	Valve Cap Plastic c/w Sealing Washer	E 100
232020	TRVC2	Valve Cap c/w Core Remover	F 100
232030	TRVC4	Valve Cap c/w Large Bore Core Remover	G 100
232040	TRVC3	Valve Cap Domed Metal	H 100
232060	N/A	Valve Cap High Pressure Domed	I 100
232080	N/A	Valve Cap High Pressure Hexagonal Chrome	J 100
232100	N/A	Valve Cap High Pressure Hexagonal Yellow	100
232120	N/A	N/A Valve Cap High Pressure Hexagonal Blue	100
232140	N/A	N/A Valve Cap High Pressure Hexagonal Red	100
232180	N/A	N/A Valve Cap Plastic Green	E 100
232220	N/A	N/A Valve Cap Plastic Silver	E 50
T72-20-202	N/A	TPMS Valve Cap	100



■ VALVE CAPS AND REDUCERS LARGE BORE

PART NO.	REF NO.	DESCRIPTION	QTY
601040	N/A	Valve Cap Hexagon Slotted	A 1
601050	N/A	Valve Cap Domed	A 1
601060	TRVC6	Valve Cap c/w Core Remover	B 1
601080	TRAD1	Valve Adaptor Reduces L/B Thread to Standard	C 1
601100	TRAD1C	Valve Adaptor Reduces L/B Thread	D 1

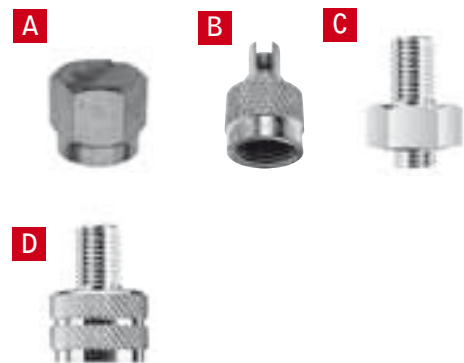

VALVE CORES

■ VALVE CORES CAR/TRUCK

PART NO.	REF NO.	DESCRIPTION	QTY
233000	TRC1	Valve Core Short	E 100
233020	N/A	Valve Core Short High Temperature	F 100
233042	N/A	High Pressure Valve Core	G 1
233044	N/A	PV/3 High Pressure Valve Core	H
233060	TRC1	Valve Core Long	I 1
T72-20-201	N/A	TPMS Nickel Valve Core	100

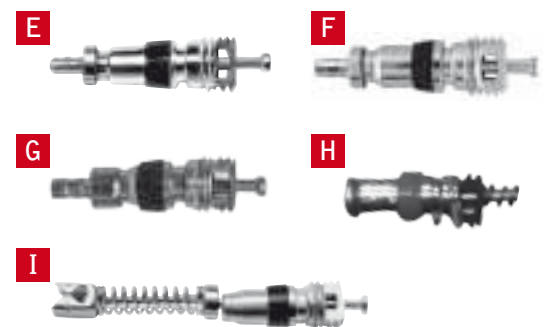

■ VALVE CORES LARGE BORE

PART NO.	REF NO.	DESCRIPTION		QTY
601000	TRC2	Valve Core Short	I	1
601010	N/A	N/A Valve Core Short Internal Spring	J	1
601020	TRC2	Valve Core Long	K	1

VALVE TOOLS AND ACCESSORIES

■ VALVE TOOLS CAR/TRUCK

PART NO.	DESCRIPTION		QTY
243000	Valve Core Tool Plastic Handle Standard	L	1
243010	Valve Core Tool Long 200mm		1
243020	Valve Service Tool	N	1
243026	Valve Core Tool Plastic Handle Cap/Core		1
243029	Valve Core Tool Plastic Handle Magnetic		1
243030	Valve Core Lock Tool	O	1
243040	Tubeless Valve Mounting Tool Screw On Straight	P	1
243060	Tubeless Valve Mounting Tool Screw On Bent	Q	1
243080	Tubeless Valve Mounting Tool Plastic	R	1
243100	Tubeless Valve Mounting Tool Snap On	S	1
243120	Truck Extension Service Tool	T	1
243140	Professional Valve Repair Tool 4 Way	U	1
243200	Tube Deflator/Aspirator	V	1
243210	Tube Deflator/Aspirator Deluxe	W	1
243300	Valve Extension Tool TL632		1
244000	Valve Fishing Tool	A	1
244004	Valve Fishing Tool Chain	B	1
244010	Valve Fishing Tool Cable Deluxe	C	1
244012	Valve Fishing Tool Cable Premium	C	1
244100	Plastic Ferrules		25

■ VALVE TOOLS LARGE BORE

PART NO.	DESCRIPTION		QTY
244060	Air/Water Filling Kit	D	1
503000	Valve Thread Repair Tool Vg12,Vg8,Vg5 and Core Key	F	1
503040	Broken Valve Core Extractor		1
503060	Valve Core Tool Standard/Long Bore		1
503080	Tube Deflator/Aspirator Professional	I	1

I



J



K



L



N



O



P



Q



R



S



T



U



V



W



A



B



C

D



F



I



WHEEL SAFETY

PART NO.	DESCRIPTION		SIZE	QTY
015020	015020 "Part Worn" Stamp Kit	A	N/A	1
015022	Part Worn Labels 100	B	N/A	100
015030	Ink For "Part Worn" Stamp Kit		N/A	1
015040	Pad For "Part Worn" Stamp Kit		N/A	1
015050	Stamp For "Part Worn" Stamp Kit		N/A	1
015382	Ric Clip R/H Silver	C	27mm	8
015384	Ric Clip R/H Yellow	C	30mm	8
015386	Ric Clip R/H Silver	C	32mm	10
015388	Ric Clip R/H Blue	C	33mm	10
015480	Checkpoint - Yellow	D	19mm	1
015490	Checkpoint - Yellow	D	21mm	1
015492	Checkpoint - Yellow	D	22mm	1
015494	Checkpoint - Yellow	D	23mm	1
015500	Checkpoint - Yellow	D	24mm	1
015510	Checkpoint - Yellow	D	26mm	1
015520	Checkpoint - Yellow	D	27mm	1
015530	Checkpoint - Yellow	D	28mm	1
015540	Checkpoint - Yellow	D	30mm	1
015560	Checkpoint - Yellow	D	32mm	1
015580	Checkpoint - Yellow	D	33mm	1
015590	Checkpoint - Yellow	D	36mm	1
015600	Checkpoint - Yellow	D	38mm	1
015660	Checkpoint - Yellow	D	41mm	1
015702	Dustite Long	E	19mm	1
015722	Dustite Long	E	27mm	1
015760	Dustite Standard	F	32mm	
015762	Dustite Long	E	32mm	
015780	Dustite Standard	F	33mm	1
015782	Dustite Long	G	33mm	1
015820	Red Checkpoint	D	27mm	1
015840	Red Checkpoint	D	30mm	1
015860	Red Checkpoint	D	32mm	1
015880	Red Checkpoint	D	33mm	1
015900	Checklink Yellow	I	19mm	1
015920	Checklink Yellow	I	24mm	1
015960	Checklink Yellow	I	32mm	1
015980	Checklink Yellow	I	33mm	1
016100	Stud Hole Elongation Tester	H	N/A	1



'O' RINGS AND BEAD SEATS

■ 'O' RINGS

PART NO.	DESCRIPTION	SIZE (")	DIAMETER (")	QTY
801000	Grader	15 Thin		1
801020	Grader	17 Thin	.26	1
801040	Grader	20 Thin		1
801060	Grader	24 Thin		1
801070	Earthmover	24 Thick	.28	1
801080	Grader	25 Thin		1
801100	Earthmover	25 Thick		1
801120	Earthmover	29 Thick		1
801140	Earthmover	33 Thick	.35	1
801160	Earthmover	35 Thick		1
801180	Earthmover	39 Thick		1
801200	Earthmover	45 Thick		1
801220	Earthmover	49 Thick		1
801240	Earthmover	51 Extra Thick	.5	1
801260	Earthmover	57 Extra Thick		1

■ BEAD SEATS / "L" SEALS

PART NO.	DESCRIPTION	SIZE (")	QTY
702000	Bead Seat	20	1
702020	Bead Seat	25	1
702040	Bead Seat	29	1
702060	Bead Seat	33	1
702080	Bead Seat	35	1
702100	Bead Seat	39	1
702120	Bead Seat	45	1
702140	Bead Seat	49	1
702160	Bead Seat	51	1
702180	Bead Seat	57	1

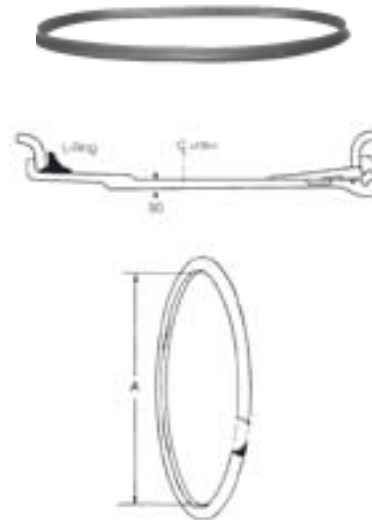
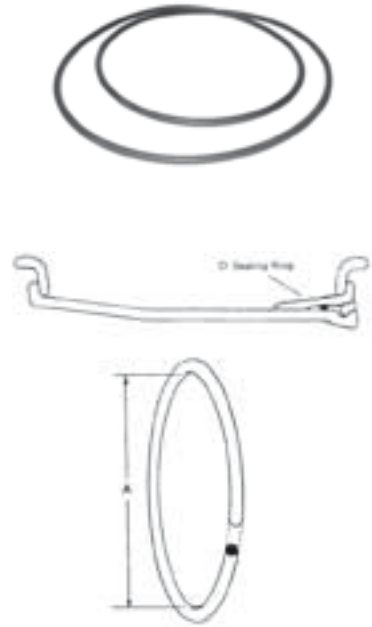

TYRE CHANGING EQUIPMENT CAR AND MOTORCYCLE

■ MS32-1 FULLY AUTOMATIC TYRE CHANGER FOR CARS, LIGHTWEIGHT TRANSPORT VEHICLES AND MOTOR VEHICLES

- Air operated tilt back.
- Mechanical balancing of tool-holder shaft
- Simultaneously tool alignment By simple push button operation
- 10- 22" external clamping with 12-24" Internal clamping
- MPT240 Assist arm Available

■ MS41E-12V SEMI AUTOMATIC CAR TYRE CHANGER

- Side swing mounting arm
 - Mechanical adjustment of the mounting arm
 - Self-centering four-jaw chuck
 - Two pneumatic clamping cylinders
 - Clockwise and anticlockwise rotation of the turntable by electric motor
 - Equipped with a pneumatic built-in safety valve (CE norms)
 - Pressure regulator with water filter and lubricator
 - Alloy rim protection kit
- | | |
|--------------------------|---------------------------|
| ■ Outside clamping range | 11 - 22" |
| ■ Inside clamping range | 13 - 25" |
| ■ Max. wheel diameter | 1100mm (43") |
| ■ Max. rim width | 13" |
| ■ Bead breaking range | 45 - 390mm (1.75 - 15.5") |

■ ADDITIONAL INFORMATION

- Semi-automatic, heavy duty tyre changer
- Wheel clamping range 11 - 25", which means you can cater for many different types of vehicles ranging from the smallest passenger car to the largest 4x4
- The back post on the S41 has been specially designed to allow you to fit more specialist wheels with wider rims
- The wider spacing of the control pedals means that the S41 is easier to use, especially when wearing safety boots
- A robust, strong and professional piece of equipment, that won't let you down and available without a huge level of investment



■ MS43-1 AUTOMATIC CAR TYRE CHANGER 1 PHASE

- Automatic tyre changer with pneumatic tilting back
- Simultaneous pneumatic horizontal and vertical arm
- Self-centering four-jaw chuck
- Two pneumatic clamping cylinders
- Clockwise and anticlockwise rotation of the turntable electric motor
- Double acting bead breaker cylinder
- Bead breaker with articulated blade
- Equipped with a pneumatic built-in safety valve (CE norms)
- Pressure regulator with water filter and lubricator
- Alloy rim protection kit

MS43-1GP equipped with:

- Quick tubeless tyre inflation system operated by a foot-pedal (blast inflation system)
- Rear air tank for blast inflation system (CE norms)
- Pressure readout unit with pressure release button

- Outside clamping range 12 - 24"
- Inside clamping range 14 - 27"
- Max. wheel diameter 1100mm (43")
- Max. rim width 14"
- Bead breaking range 45 - 390mm (1.75 - 15.5")

■ ADDITIONAL INFORMATION

- Heavy duty automatic tyre changer
- This heavy duty automatic tyre changer has a foot pedal operated, pneumatic tilting back post for effortless and consistent use
- The fitting head is simultaneously locked horizontally and vertically by the push of a button, whilst at the same time adjusting the fitting head to a preset rim clearance, so reducing the risk of costly damage to the wheel
- With a clamping range 14 - 27" the tyres of vehicles ranging from the smallest passenger car to the largest 4x4 can be accommodated
- The increased height and location of the tilting back post on the S43 means that larger tyre and wheel assemblies as found on some off road vehicles, can be handled quickly and safely
- Tyre and rim assemblies with an overall diameter of up to 43" can be accommodated on the turntable
- Like all Sice heavy duty models, the S43 is fitted with two control plates operating the rim clamping mechanism, this system ensures concentric clamping of the wheel, greatly reducing the risk of rim damage on even the toughest of tyre and wheel assemblies
- The large bead breaker blade is adjustable to suit the profile of the tyre assembly being removed so maximising the force of the powerful, double acting bead breaking cylinder. The bead breaker combined with the large tyre rest pad efficiently deals with even run-flat type of tyres. With a bead breaking range of 1.75" to 15.5" the S43 meets the need of busiest garage or tyre specialist
- As with all Auto4/Sice tyre changers the S43 is supplied with an alloy wheel protection kit and tyre inflator



■ MS45-1 AUTOMATIC CAR TYRE CHANGER 1 PHASE

- Automatic tyre changer with pneumatic swing arm movement
- Simultaneous pneumatic horizontal and vertical arm locking
- Pneumatic and/or manual positioning of the vertical bar
- Equipped with CRU, quick exchange device for fitting head
- Self-centering four-jaw chuck
- Two pneumatic clamping cylinders
- Clockwise and anticlockwise rotation of the turntable through 2 speed, 1 phase electric inverter motor
- Electric supply 1 phase with motor-inverter
- Double acting bead breaker cylinder
- Double-way adjustable blade angle and enlarged wheel pad
- Equipped with a pneumatic built-in safety valve (CE norms)
- Pressure regulator with water filter and lubricator
- Alloy rim protection kit

MS45-1GP equipped with:

- Quick tubeless tyre inflation system operated by a foot-pedal (blast inflation system)
- Rear air tank for blast inflation system (CE norms)
- Pressure readout unit with pressure release button and tool-container box

- | | |
|--------------------------|-----------------------------------|
| ■ Outside clamping range | 11 - 22" |
| ■ Inside clamping range | 13 - 25" |
| ■ Max. wheel diameter | 1100mm (43") |
| ■ Max. rim width | 13" |
| ■ Bead breaking range | Pos. 1a 45 - 390mm (1.75 - 15.5") |
| | Pos. 2a 10 - 340mm (0.25 - 13.5") |

■ ADDITIONAL INFORMATION

- Fully automatic, heavy duty tyre changer
- The S45 has a unique automatic swing arm operation, designed for a long robust life, reducing the risk of damaging rims over years of use
- Wheel clamping range 11 - 25", which means you can cater for many different tyres of vehicles ranging from the smallest passenger car to the largest 4x4
- The back post on the S45 has been specially designed to allow you to fit more specialist wheels with wider rims
- The twin control plates on the S45 ensure concentric clamping, which significantly reduces the risk of damaging wheels
- The adjustable bead breaker blade and large tyre rest pad ensures that the bead breaker blade is always at the correct angle regardless of the rim width, this means maximum bead breaker power
- The S45 comes as standard with a quick change head system, which is positioned and locked pneumatically by push button operation, ensuring the fitting head is positioned correctly and securely, again limiting the risk of rim damage
- The two speed inverter motor results in fast and efficient tyre removal
- The S45 is a market leading piece of equipment and the most popular in the Sice range. It will be most useful in major dealerships and larger tyre shops



■ MS45TOP-1 AUTOMATIC CAR TYRE CHANGER 1 PHASE

- Automatic tyre changer with pneumatic swing arm movement
- Simultaneous pneumatic horizontal and vertical arm locking
- Pneumatic and/or manual positioning of the vertical bar
- Equipped with CRU, quick exchange device for fitting head
- Self-centering four-jaw chuck
- Two pneumatic clamping cylinders
- Clockwise and anticlockwise rotation of the turntable through 2 speed, 1 phase electric inverter motor
- Electric supply 1 phase with motor-inverter
- Double acting bead breaker cylinder
- Double-way adjustable blade angle and enlarged wheel pad
- Equipped with a pneumatic built-in safety valve (CE norms)
- Pressure regulator with water filter and lubricator
- Alloy rim protection kit
- Comes complete with WDK accessories for UHP and Runflat tyres
- Complete with MPT250 assist arm fitted as standard

MS45TOP-1 equipped with:

- Quick tubeless tyre inflation system operated by a foot-pedal (blast inflation system)
- Pressure readout unit with pressure release button and tool-container box

- Outside clamping range 12 - 24"
- Inside clamping range 14 - 27"
- Max. wheel diameter 1100mm (43")
- Max. rim width 13"
- Bead breaking range Pos. 1a 45 - 390mm (1.75 - 15.5")
Pos. 2a 10 - 340mm (0.25 - 13.5")

■ ADDITIONAL INFORMATION

- Fully automatic, heavy duty tyre changer
- The S45 has a unique automatic swing arm operation, designed for a long robust life, reducing the risk of damaging rims over years of use
- Wheel clamping range 14 - 27", which means you can cater for many different tyres of vehicles ranging from the smallest passenger car to the largest 4x4
- The back post on the S45 has been specially designed to allow you to fit more specialist wheels with wider rims
- The twin control plates on the S45 ensure concentric clamping, which significantly reduces the risk of damaging wheels
- The adjustable bead breaker blade and large tyre rest pad ensures that the bead breaker blade is always at the correct angle regardless of the rim width, this means maximum bead breaker power
- The S45 comes as standard with a quick change head system, which is positioned and locked pneumatically by push button operation, ensuring the fitting head is positioned correctly and securely, again limiting the risk of rim damage
- The two speed inverter motor results in fast and efficient tyre removal
- The S45 is a market leading piece of equipment and the most popular in the Sice range. It will be most useful in major dealerships and larger tyre shops



■ MS45TL-1 AUTOMATIC CAR TYRE CHANGER "LEVER-LESS" 1 PHASE

- New Automatic tyre changer with lever-less technology
- Automatic swing arm saves repositioning time and space
- Lever-less pneumatic control
- Self-centering four-jaw chuck
- Two pneumatic clamping cylinders
- Clockwise and anticlockwise rotation of the turntable through 2 speed, 1 phase electric inverter motor
- Electric supply 1 phase with motor-inverter
- Double speed of the turntable (smooth ramp)
- Double acting bead breaker cylinder
- Three-way adjustable blade angle and enlarged wheel pad

Equipped with:

- Mounting/demounting lever-less tool head (patented)
- Pneumatic built-in safety valve (CE norms)
- Pressure regulator with water filter and lubricator
- Alloy rim protection kit
- Variable angle bead pressing roller
- Lower arm for bead lifting roller with pneumatic radial brake (patented)
- Complete with MPTTL assist arm fitted as standard

- Outside clamping range 12 - 24"
- Inside clamping range 14 - 27"
- Max. wheel diameter 1100mm (43")
- Max. rim width 13"
- Bead breaking range Pos. 1a 40 - 440mm (1.5 - 17.5")
Pos. 2a 5 - 380mm (0 - 15")

■ ADDITIONAL INFORMATION

- The S45TL-1 with its unique automatic swing arm operation is designed to meet the demands of today's market and is the ideal machine for the specialist tyre outlet or major dealerships
- The S45TL comes as standard with a patented lever-less mounting/demounting tool head. The height of the mount/demount head is set using lever-less pneumatic control
- The back post on the S45TL has been specially positioned to allow the fitting of more specialist wheels and tyres. Assemblies with an overall tyre diameter of up to 43" as found on the larger off road vehicles can be changed on the S45TL. Like all Sice heavy duty models, the S45TL is fitted with two control plates to operate the rim clamping mechanism, this system ensures concentric clamping of the wheel, greatly reducing the risk of rim damage on even the toughest of tyre and wheel assemblies
- The adjustable bead breaker blade and large tyre test pad ensures that the bead breaker blade is always at the correct angle regardless of the rim width, this means maximum bead breaker power. The two speed 1 phase inverter fed motor results in fast and efficient tyre removal



■ MS48TL-1 AUTOMATIC CAR TYRE CHANGER "LEVER-LESS" 1 PHASE

- New Automatic tyre changer with lever-less technology
- Automatic swing arm saves repositioning time and space
- Lever-less pneumatic control
- Self-centering four-jaw chuck
- Turntable positioning adjustable in height (patented)
- Two pneumatic clamping cylinders
- Clockwise and anticlockwise rotation of the turntable through 2 speed, 1 phase electric inverter motor
- Electric supply 1 phase with motor-inverter
- Double speed of the turntable (smooth ramp)
- Double acting bead breaker cylinder
- Three-way adjustable blade angle and enlarged wheel pad

Equipped with:

- Inflating system with pedal control (FPI)
 - Mounting/demounting lever-less tool head (patented)
 - Pneumatic built-in safety valve (CE norms)
 - Pressure regulator with water filter and lubricator
 - Alloy rim protection kit
 - AR10 Adaptor Set for 10" rims
 - PT340 Bead lifting/pressing device for low profile and run flat tyres (Sice patent)
 - Pressure readout unit with pressure release button and tool-container box
 - Variable angle bead pressing roller
 - Lower arm for bead lifting roller with pneumatic radial brake (patented)
- | | | |
|---|--------------------------------|---|
| ■ | Outside clamping range | 12 - 24" |
| ■ | Inside clamping range | 14 - 27" |
| ■ | Max. wheel diameter | 1120mm (44") |
| ■ | Max. wheel width on turntable: | High position 330mm, low position 370mm (14.5") |
| ■ | Bead breaking range | Pos. 1a 40 - 440mm (1.5 - 17.5")
Pos. 2a 5 - 380mm (0 - 15") |



■ ADDITIONAL INFORMATION

- The S48TL-1 with its unique automatic swing arm operation and patented variable height turntable is designed to meet the demands of today's market and is the ideal machine for the specialist tyre outlet or major dealerships
- The S48TL comes as standard with a patented lever-less mounting/demounting tool head. The height of the mount/demount head is set using lever-less pneumatic control. When changing wide tyres on tyre changers with a single height turntable, the top of the wheel rim is so high that it is at an uncomfortable and inefficient height, making it difficult to fit and remove tyres. Not so with the S48TL, by simply lowering the variable height turntable, the top of the wheel rim is positioned at an ergonomic height, making the fitting operation simple
- The back post on the S48TL has been specially positioned to allow the fitting of more specialist wheels and tyres. Assemblies with an overall tyre diameter of up to 44" as found on the larger off road vehicles can be changed on the S48TL. Like all Sice heavy duty models, the S48TL is fitted with two control plates to operate the rim clamping mechanism, this system ensures concentric clamping of the wheel, greatly reducing the risk of rim damage on even the toughest of tyre and wheel assemblies
- The adjustable bead breaker blade and large tyre test pad ensures that the bead breaker blade is always at the correct angle regardless of the rim width, this means maximum bead breaker power. The two speed 1 phase inverter fed motor results in fast and efficient tyre removal

TYRE PRESS UNITS

■ MPT230 - RIGHT HAND TYRE PRESS UNIT FOR MS43-1

Bead lifting/pressing device to assist the operator particularly on "difficult" low profile tyres. It presses the tyre to facilitate tool/head and tyre lever positioning between tyre and rim. It presses the tyre in the rim well to facilitate bead mounting on the claw. It presses and keeps the bead at rim well level during mounting operation thanks to its characteristic to turn with the tyre.

■ MPT240 - RIGHT HAND TYRE PRESS UNIT FOR MS32-1 & MS43-1

■ MPT250 - LEFT HAND TYRE PRESS UNIT FOR MS43-1 & MS45-1

■ ADDITIONAL INFORMATION

- Used in conjunction with any Sice tyre changer, Sice tyre press unit keep the fitting of the most difficult tyre a one man operation, even if it's a low profile, run-flat tyre.
- The unique patented design of this tyre pressing unit means, whether fitting or removing the tyre, the risk of damage to the rim or tyre is removed.



■ MPT230



■ MPT240



■ MPT250

TYRE CHANGING ACCESSORIES

PART NO.	DESCRIPTION		QTY
011100	Balance Weight Pliers Premium	B	1
011105	Balance Weight Plier Soft Head Protection	C	1
011107	Clip Fitting Tool for 2pc Weights	D	1
011109	Tyre Compression Tool		1
011110	Rim Width Gauge	E	1
011160	Tyre Mounting/Drop Centre Aid	F	1
M2200277	Motorcycle Adaptors (Set of 4)	G	1
M2201411	4" Clamping Reducer (Set of 4)	H	1
M2201645	Nylon Protection Kit - Retro	L	1
M2201659	Alloy Rim Protector Kit	J	1
M2201716	Rim Edge Protector	K	1
M2201717	Rim Edge Protector Low Cost	K	1
M2201894	4" Clamping Increaser (Set of 4)	I	1
M8-11100369	Nylon Protection Kit - New		1



B



C



D



E



F



G



H



I



J



K



L

TRUCK AND EARTHMOVER

■ MS52A-3 - S52A TRUCK TYRE CHANGER INC HYDRAULIC CLAMPING - 3 PHASE

- Semi-automatic tyre changer for truck and bus tyres
- Hydraulic wheel locking. Quick and safe.
- Bead breaking using engineered plastic rollers to ensure robustness and to avoid scratches on the Aluminium rims.
- For Wheel Sizes 14"- 26"

■ MS54-3 TRUCK TYRE CHANGER 3 PHASE

- Electro-hydraulic truck tyre changer for wheels of trucks, buses, tractors and earthmoving vehicles, with groove rim or with split ring rim and for tubed or tubeless wheels
 - Universal self-centering chuck
 - Clockwise and anticlockwise rotation of the chuck
 - Moving tool arm carriage (left - right)
 - Portable control unit
- | | |
|-----------------------|-----------------------------------|
| ■ Rim clamping range | 14 - 46" (56" with PA extensions) |
| ■ Max. wheel diameter | 2300mm (90") |
| ■ Max. wheel width | 1065mm (42") |
| ■ Max. wheel weight | 1600kg |

■ MS55-3 UNIVERSAL AUTOMATIC TRUCK TYRE CHANGER

- Heavy duty electro-hydraulic automatic truck tyre changer for quick demounting and mounting of wheels for trucks, buses, tractors and earth moving vehicles, with groove rim or with split ring rim and for tubed or tubeless wheels
- Version S 55: 1 translation speed. Manual tool rotation and lifting
- Version S 55A: 2 translation speeds. Automatic tool rotation and lifting. Radio kit available as an optional
- Both versions are available with a floor-standing or suspended control console
- 14" to 56" rims (using standard extension)
- Rim. clamping range 14-56" (with standard extensions)
- Max. wheel diameter 2500 mm
- Max. wheel width 1220 mm
- Max. wheel weight 1300 kg



Why not visit
our website at
auto4.co.uk

WHEEL BALANCERS CAR AND MOTORCYCLE

- **MS606M-12v - S606M Wheel Balancer C/W FBC Manual 12 Volt YELLOW**
- The MS606 is the most popular choice for the Mobile Van balancer solution:
- Compact wheel balancer with digital display
- Made for mobile wheel service units or usage where space is limited:
- Manual spin (no motor)
- Lever operated clamping brake to facilitate wheel clamping and unclamping
- 11 balancing programmes for steel and alloy passenger car, van and motorcycle wheels
- Complete with special OPT and HIDDEN WEIGHT programmes
- May also operate with single phase source



follow us on

twitter

@Auto4Ltd



■ MS60E OUR ENTRY LEVEL WHEEL BALANCER WITH HIGH BRIGHTNESS DIGITAL DISPLAY

- Manual data input
- Software compatible with all types of steel and light alloy wheels for passenger cars, off-road vehicles, light commercial vehicles, motorcycles and scooters.
- DISPLAY: modern and practical high brightness digital display.
- WEIGHT HOLDER TRAY: ergonomic and spacious tray in highly resilient material for counterweights and work accessories.
- CHASSIS: sturdily built and stable for balancing wheels up to 70 kg

■ MS62E-1 AUTOMATIC WHEEL BALANCER 1 PHASE

- 2 Year Warranty
- 3,6 or 12 O'Clock adhesive weight placement to facilitate all fitters preferences
- For passenger car and light commercial vehicle wheels
- Manual data acquisition and input
- 11 balancing programmes with weight placement
- Optimisation programme for rim/tyre matching
- Automatic start by lowering the hood guard
- Large weight, tool and aerosol storage tray
- 4 Cones as standard

- Max. wheel diameter 37"
- Max. rim diameter 35"
- Max. rim width 20"
- Max. wheel weight 75kg

■ ADDITIONAL INFORMATION

- The S62 is an inexpensive full size wheel balancer of the highest quality
- The 11 wheel balancing programmes available on this machine ensure that all wheel options can be covered
- Automatic acquisition of the imbalance in one spin for both static and dynamic programmes and automatic end-cycle stop
- The ergonomics of this new range balancer have been designed specifically for the operators needs, such features as the "Close to wall" fitment, the large weight and tool storage tray, simple data screen layout and the extended shaft makes this balancer a perfect fit for all workshops



**Why not visit
our website at
auto4.co.uk**

■ MS63E-1 AUTOMATIC WHEEL BALANCER 1 PHASE

- 2 Year Warranty
- For passenger car and light commercial vehicle wheels
- Auto data acquisition and input
- 3,6 or 12 O'Clock adhesive weight placement to facilitate all fitters preferences
- 11 balancing programmes with weight placement
- Optimisation programme for rim/tyre matching
- Automatic start by lowering the hood guard
- Large weight, tool and aerosol storage tray
- 4 Cones as standard

■ Max. wheel diameter	37"
■ Max. rim diameter	35"
■ Max. rim width	20"
■ Max. wheel weight	75kg

■ ADDITIONAL INFORMATION

- The S63 is a full size wheel balancer of the highest quality
- The 11 wheel balancing programmes available on this machine ensure that all wheel options can be covered
- Automatic acquisition of the imbalance in one spin for both static and dynamic programmes and automatic end-cycle stop
- The ergonomics of this new range balancer have been designed specifically for the operators needs, such features as the "Close to wall" fitment, the large weight and tool storage tray, simple data screen layout and the extended shaft makes this balancer a perfect fit for all workshops
- The large plastic weight tray means ample storage available for the many different types of balance weights required today, whilst the space saving wheel guard keeps the space required to a minimum



■ MS65-1 AUTOMATIC WHEEL BALANCER 1 PHASE

- 2 Year Warranty
- For passenger car and light commercial vehicle wheels
- Auto data acquisition and input with full 19" LCD monitor display
- 3,6 or 12 O'Clock adhesive weight placement to facilitate all fitters preferences
- 11 balancing programmes with weight placement
- Optimisation programme for rim/tyre matching
- Automatic start by lowering the hood guard
- Large weight, tool and aerosol storage tray
- 4 Cones as standard

■ Max. wheel diameter	37"
■ Max. rim diameter	35"
■ Max. rim width	20"
■ Max. wheel weight	75kg

■ ADDITIONAL INFORMATION

- The S65 is a full size wheel balancer of the highest quality
- The 11 wheel balancing programmes available on this machine ensure that all wheel options can be covered
- Automatic acquisition of the imbalance in one spin for both static and dynamic programmes and automatic end-cycle stop
- Simple to use, robust, low cost of ownership and the highest quality in manufacture all mean that a Sice wheel balancer will give you a long reliable return on your investment



■ MS73-1 ELECTRONIC WHEEL BALANCER FOR CAR, VAN AND MOTORCYCLE WHEELS

- Automatic measurements of distance, diameter with Sonar
- Laser Pointer for accurate placing of adhesive weights
- Integrated LED light to illuminate the Rim
- Available in Automatic Clamping version (S73C)

■ ADDITIONAL INFORMATION

- High Performance Wheel balancer with LCD display, new digital wheel inner Data gauge with quick program function which eliminates the need of keyboard selection for different balancing programs
- Adhesive weights are positioned quickly with laser pointer and at 6 o'clock which gives the operator a clear view eliminating placement errors
- Automatic Positioning, at the end of the spin the wheel is braked and automatically brought to the balance position with an led light to illuminate the work area to facilitate rim cleaning and weight placement
- Wheel guard system enables positioning right back to a wall saving valuable workshop space



■ STATIC WHEEL BALANCERS

PART NO.	DESCRIPTION		QTY
006200	Werther Static Motorcycle Wheel Balancer	A	1
K01000	Challenger Bubble Balancer	B	1



WHEEL BALANCING CONES AND ADAPTORS

■ PASSENGER CAR VAN AND LIGHT COMMERCIAL

PART NO.	DESCRIPTION		QTY
M2002993	GHI-M Quick Release Lock Nut D.40 x 3	A	1
M2002743	FRU-SA Universal Plate for 3/4/5 Stud Closed Centre Wheels 40mm	B	1
M2401189	DX/CBF Transit Cone and Spacer 40mm	C	1
M2200556	Car Clamping Accessories for S680	D	1
M2001047	210mm Clamping Hood	E	1
M2402737	AC5 Centering Rings Set of 5 for FRU-SA (M2002743) 40mm	F	1
M2002253	FPM-I Universal Quick Centering Flange with Interchangeable Pins 40mm	G	1
M2402266	Stud Hole Location Pins set of 5 for use with FPM-i	H	1
M2400820	Centering Bush Set (7 pieces) for specialist wheel mounting 40mm	I	1
M2002415	Wall Panel for Adaptor Storage	J	1



MOTORCYCLE

PART NO.	DESCRIPTION		QTY
M2402711	Self Centering Adaptor for Motorcycle Rims	K	1
M2001353	Specialist Adaptor for Honda VFR	L	1
M2001346	Specialist Adaptor for Aprilia	M	1
M2000387	Specialist Adaptor for Ducati - BMW Rims	N	1

Please specify shaft diameter of the wheel balancer when ordering.
A full range of wheel balancer adaptors for car and motorcycle are available on request.

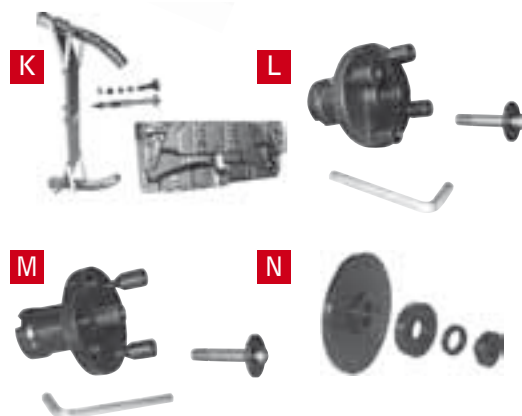

WHEEL ALIGNERS

MSALIGN92

- State of the art 2 Camera 3D Wheel Alignment System, comes complete with PC, Monitor, Printer, Steering Wheel Clamp, Brake Pedal Depressor and 4 x 10" - 26" Wheel Clamps.



MSALIGN92

MSALIGN926

- 8 Camera CCD Wheel Alignment System for use where space is at a premium.
- Comes complete with PC, Monitor, Printer, Steering Wheel Clamp, Brake Pedal Depressor and 4 x 10" - 26" Wheel Clamps.



MSALIGN926

PART NO.	DESCRIPTION	QTY
MSALIGN92	A92 Wheel Aligner - 2 High Resolution Digital Camera	1
MSALIGN926	A926 4 Wheel Aligner CCD	1

WHEEL WASHERS

MSL850

- Electronic Wheel Washer featuring a cleaning method with low-pressure water and plastic granules, designed to handle oversized and heavy car, SUV's and van wheels.

PART NO.	DESCRIPTION	QTY
MSL850	Sice Wheel Washer	1



MSL850

LIFTS

■ MLIFT2P2

- 2 Post Electromechanical Lift 3000 kg including H Frame base. Max lifting height of 1945mm. Low min height of 99mm. Generous 2560mm of working distance between the columns.
- Available 3 Phase or 1 Phase. 2 Years Parts and Labour Warranty.

PART NO.	DESCRIPTION	QTY
MLIFT2P2	2 Post Electromechanical Lift 3000 kg	1



■ MLIFT2P2

■ MLIFT2P4

- Post Electromechanical Lift 5000 kg. Maximum Lifting height of 1890mm. Extra low minimum height of 70mm. Generous 2700mm of working distance between the columns.
- 3 Phase Only. 2 year parts and labour warranty.

PART NO.	DESCRIPTION	QTY
MLIFT2P4	2 Post Electromechanical Lift 5000 kg	1



■ MLIFT2P4

■ MLIFT4P2

- 4 Ton, 4 Post Wheel Alignment Ramp suitable for all Alignment Systems including 3D. Comes complete with rear slip plates and front turn plates.
- Options include Jacking beams, in built scissor lifts and lighting kits. Low Minimum ground height of just 126mm. Long usable platform length of 4800mm
- Maximum Lifting height of 1960mm. Adjustable Turn plate positions to suite car and light commercial vehicles.

PART NO.	DESCRIPTION	QTY
MLIFT4P2	4 Post Wheel Alignment Lift* 4800mm	1

* In-Built Scissor Lifts available as an option.

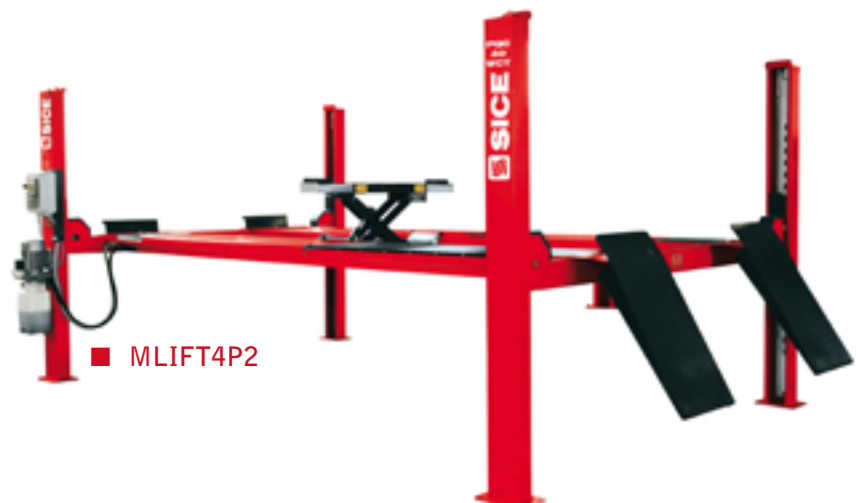

■ MLIFT4P2

PROTECTING YOUR EQUIPMENT

■ PROTECT YOUR BUSINESS

At Auto4 we think it is important that you look after your tyre changing and wheel balancing equipment. We believe this because our experience tells us that if you do not then...

- You run a higher risk of your equipment breaking down which could lead to a deterioration in your customer service levels, which over a period of time will undermine your business
- You run a higher risk of your equipment breaking down, leaving you unable to function effectively, which could lead to a reduction in your sales revenues
- Your general maintenance costs will be higher, as small problems will not be spotted and rectified, leading to larger issues over the longer term
- You reduce the life expectancy of the equipment, meaning that you will need to replace it prematurely, an unnecessary cost on your business

You can limit these risks by having your tyre changers and wheel balancers serviced regularly by qualified Auto4 Service Engineers.



If you would like to arrange for one of our fully qualified Service Engineers to call, you can do so by contacting our Sales Support Team on 0845 0770 190.





#67250

Torque Fin®

Torque Wrench Stabilizer

Looking for accurate, precise truck wheel torque every time?
Torque it the Torque Fin® Way!

- Links with, stabilizes, and properly aligns manual torque wrenches to ensure accurate torque
- Eliminates the need for two technicians to torque wheel
- Saves time and money
- Easy to use - instructions on tool
- Reduces risk of injury and liability due to wheel-off accidents
- Works with all 3/4" and 1" torque wrenches
- Weight: 8 lbs (3.6 kg)



#37330

Hub Buddy XL

Impact-Rated Hub / Disc Surface Cleaner

The fastest way to ensure proper torque and quicker balance!

- Impact rated - no need to change tools
- Blasts away rust, corrosion and other build-up from hub and wheel surface
- Helps proper torque of lug nuts by removing corrosion
- A must for easy and accurate tire balancing
- Includes: 1 Hub Buddy XL attachment and 1 cleaning disc free

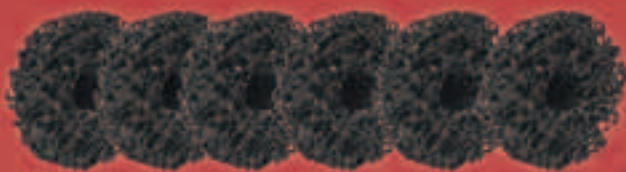

- Replacement cleaning discs available in packs of 5 (Product #17135)



#15025

5 Quart Turbo 3

Air/Hydraulic Pump, Steel

Designed specific to conditions normally associated with OTR sites!

- Builds 10,000 PSI of pressure to fit the majority of tools on the market
- Operates on 80-120 PSI of inlet air pressure. (Standard on most compressors and shop air)
- Durable metal air motor assemblies
- Steel reservoir
- Designed specific to conditions normally associated with OTR sites
- Max Pressure: 10,000 PSI
- Weight: 30 lbs (13.6 kg)



#75005

The Wedgie

Tire Bead Wedge

Simple yet effective device that assists in breaking beads!

- Used to assist in breaking beads on earthmover, ag, construction and forestry tires.
- Simple yet effective device
- High impact nylon material
- Avoid metal on metal contact
- Allows for a bead breaker to fit between tire and wheel - even on skidder tires
- Weight: 10.4 lbs.
- Suggested for use with #51456 Soft Blow Hammer



CODE	PAGE	CODE	PAGE
ADAPTORS	38/39	CABLE TIES	55
ADHESIVE WEIGHT REMOVER	55	CAR AND MOTORCYCLE VALVES	71/72
ADHESIVE WEIGHTS	26	CAR WEIGHTS	19
AIR BUFFING TOOLS	29	CAR WHEEL CHOCKS	56
AIR DRILLS	31	CARB/FUEL INJECTOR CLEANER AEROSOL	14
AIR FRESHENER	18	CARBIDE CUTTER	59
AIR GAUGE	32	CAULKING GUN	53
AIR HAMMER	31	CEMENTS	11
AIR RATCHETS	31	CERAMIC GREASE	13
AIR TOOL CONDITIONER	13	CHAIN LUBE SPRAY	14
AIR TOOL OIL	13	CHANNEL CUBE/TOILET BLOCKS	18
AIR TOOLS	29	CHEMICAL RESISTANT PUMP SPRAYER	56
ALLEN KEYS	55	CLAMPING INCREASER	93
ALLOY RIM PROTECTOR KIT	93	CLAMPING REDUCER	93
ARBOUR	59	CLEAR GREASE	14
AWLS	54	CLIP FITTING TOOL	93
AXLE STANDS	51	COCKPIT SHINE	14
BACK BEAD BREAKING RAMS	69	COMPRESSOR OIL	13
BALANCE WEIGHT PLIER	93	CONNECTORS	35/36
BALANCE WEIGHTS	19-27	COOLANT LEAK REPAIR	14
BATTERIES	57	COPPER GREASE	13
BATTERY TERMINAL PROTECTOR	14	COTTON APPLICATOR	53
BEAD BREAKER	69	COUPLINGS	37
BEAD BREAKING TOOLS	44	CREAM CLEANER	18
BEAD BREAKING TOOLS	69/70	CUT OFF TOOL	31
BEAD CHEETAH ACCESSORIES	45	CUTTING DISC	60
BEAD CHEETAHS	45	DISHCLOTHS	18
BEAD HOLDER	44	DUST PAN & BRUSH SET	18
BEAD KEEPER	44	DUSTBIN	18
BEAD LUBRICANT	12	DUSTERS	18
BEAD SEALER	11	EAR DEFENDERS	16
BEAD SEATERS	44	ELECTRICAL CLEANER	14
BEAD SEATS	86	EMERY TAPE	60
BEAD WEDGE	44	EPOXY PUTTY	12
BIN - TILT OUT	55	EPOXY RESIN ADHESIVE	13
BLADE FUSES	56	EXHAUST CLAMPS	42
BLADE FUSES	57	EXTENSION BARS	68
BLEACH	18	EYE WASH PODS	16
BLOW GUN	32	FACE MASK DISPOSABLE	16
BLUE ROLL AND DISPENSER	17	FIRE EXTINGUISHER	16
BOLTS	58	FLAP WHEEL	59
BOW TIE INSERTS	10	FLARED CONTOUR WHEEL	60
BRAKE CLEANER	14	FLEXI GREASE GUN HOSES	14
BRAKE CLEANER	14	FLOOR CLEANING GEL	18
BRAKE/AIR SEALANT ADHESIVE	13	FLOOR MATS	17
BROOM HEAD AND HANDLES	17/18	FOAM TAPE	60
BUFFING DISC	59	FOOT PUMPS	69
BUFFING DISC	60	FRENCH CHALK	13
BULBS	57	FURNITURE POLISH	18
BUMP CAP	16	GAFFER TAPE	57
CABLE GRIPS	57	GENERAL PURPOSE RAGS	18
CABLE REEL	55	GLASS CLEANER	18



CODE	PAGE	CODE	PAGE
GLOVES	17	OXIDE STONE	60
GREASE GUN	14	PAINT BRUSHES	56
GRINDING DISC	60	PAINT BRUSHES	56
HALOGEN BULBS	57	PASTE BRUSH	53
HAMMERS	51/53	PATCHES	5
HAND CLEANSER	17	PENETRATING OIL	13
HEAD TORCH	55	PETROLEUM JELLY	13
HEX TORX KEYS	55	PIPE WRENCH	55
HEXAGON KEYS	55	PLIERS	55
HIGH VISIBILITY VESTS	16	PLUG FUSES	57
HOSE CLIPS	41	PLUG PATCHES	8
HOSE CLIPS	56	POLY PLUG	60
HOSE CONNECTORS	38	POWER SPRAY	14
HOSES	36/37	PRE-BUFF CLEANER	16
HUB CAP REMOVAL TOOL	55	PRESSURE GAUGES	35
HYDRAULIC GREASE GUN CONNECTOR	14	PROBES	54
HYDRAULIC JACK OIL	13	PTFE TAPE	41
INFLATION GAUGES	32	PVC INSULATION TAPE	60
INJECTOR CLEANER DIESEL	14	RADIAL REPAIR UNITS	6
INJECTOR CLEANER PETROL	14	RADIATOR FLUSH	14
INNER LINER SEALER	11	RASPS	54
J-TYPE BLUE DISPOSABLE CLOTH	18	RECHARGEABLE 360 INSPECTION LAMP	55
JACKS	47-51	RECHARGEABLE TORCH	55
JUMP LEADS	55	REGROOVER BLADES	42/43
KNEELING MAT	55	REGROOVERS	42/43
KNIFES	53	RIM EDGE PROTECTOR	93
LARGE BORE VALVES	78-80	RIM WIDTH GAUGE	93
LEAK SEEK	13	RIMSEAL	12
LITHIUM GREASE	13	RUBBER SUPPORT BLOCKS	56
LITHIUM SERVICE GREASE	13	SAFETY CAGES	45
LOCK AND SEAL ADHESIVE	13	SAFETY CONES	16
LOCKING WHEEL NUT REMOVERS	68	SAFETY GOGGLES	16
LOCTITE	13	SAFETY SPECTACLES	16
MAESTRO GAUGE	33	SCOURER SPONGE	18
MARKING CRAYONS	59	SCREWDRIVERS	55
MASK TAPE	60	SCREWS	58
MASTAIR GAUGE	33	SEAL INSERTS	10
MEASURING JUG	56	SEAT COVERS	16
METAL FILE SET 5 PIECE	55	SEAT COVERS	17
METAL TIES	57	SELF TAPPERS	56
MOLEGRIPS	55	SHORT HANDLE SHOVEL	18
MOP BUCKET	18	SICE MLIFT2P2	100
MOP HEAD AND HANDLE	18	SICE MLIFT2P4	100
MOTORCYCLE ADAPTORS	93	SICE MLIFT4P2	100
NAIL BRUSH	18	SICE MPT230 - RIGHT HAND ASSIST ARM FOR MS43-1	93
NEEDLE TOOLS	54	SICE MPT240 - RIGHT HAND ASSIST ARM FOR M32-1	93
NUTS	58	SICE MPT250 - LEFT HAND ASSIST ARM FOR MS43-1	93
NYLON PROTECTION KIT	93	SICE MS32-1 FULLY AUTOMATIC TYRE CHANGER	87
NYLON PROTECTION KIT	93	SICE MS41E-12V SEMI AUTOMATIC CAR TYRE CHANGER	87
O' CLIPS	41	SICE MS43-1 AUTOMATIC CAR TYRE CHANGER	88
O' RINGS	86	SICE MS45-1 AUTOMATIC CAR TYRE CHANGER	89
OIL ABSORBENT GRANULES	18	SICE MS45TL-1 AUTOMATIC CAR TYRE CHANGER "LEVER-LESS"	91

CODE	PAGE	CODE	PAGE
SICE MS45TOP-1 AUTOMATIC CAR TYRE CHANGER 1 PHASE	90	TYRE INFLATION LARGE BORE	33
SICE MS48TL-1 AUTOMATIC CAR TYRE CHANGER "LEVER-LESS"	92	TYRE INFLATOR	33
SICE MS52A-3 - S52A TRUCK TYRE CHANGER	94	TYRE INJURY FILLER	11
SICE MS54-3 TRUCK TYRE CHANGER 3 PHASE	94	TYRE INSPECTION SPREADER	44
SICE MS55-3 UNIVERSAL AUTOMATIC TRUCK TYRE CHANGER	94	TYRE LEVERS	60/61
SICE MS606M-12V - S606M WHEEL BALANCER	95	TYRE LIFTING HOOK	68
SICE MS60E OUR ENTRY LEVEL WHEEL BALANCER	96	TYRE MOUNTING/DROP CENTRE AID	93
SICE MS62E-1 AUTOMATIC WHEEL BALANCER 1 PHASE	96	TYRE ROUTER	59
SICE MS63E-1 AUTOMATIC WHEEL BALANCER 1 PHASE	97	TYRE SEALANT	12
SICE MS65-1 AUTOMATIC WHEEL BALANCER 1 PHASE	97	TYRE STOOL	44
SICE MS73-1 ELECTRONIC WHEEL BALANCER	98	TYRE TEST TANK	44
SICE MSALIGN92 WHEEL ALIGNER	99	TYRE TREAD DEPTH GAUGES	56
SICE MSALIGN926 WHEEL ALIGNER	99	TYREFIT PASTE BRUSH	53
SILICONE GREASE AEROSOL	13	UNIVERSAL PATCHES	5
SILICONE SEALANT CLEAR	13	VALVE CAPS AND REDUCERS LARGE BORE	83
SILICONE SPRAY AEROSOL	13	VALVE CAPS CAR/TRUCK	83
SILICONE/GASKET SEALANT HT BLACK	14	VALVE CORES CAR/TRUCK	83
SOCKET DRIVE ADAPTORS	68	VALVE CORES LARGE BORE	84
SOCKETS	63-67	VALVE TOOLS AND ACCESSORIES	84
SPANNERS	55	VALVE TOOLS LARGE BORE	84
SPHERICAL RASP "GOLF BALL"	60	VALVES - BASES AND CORE HOUSINGS	80
SPLIT PINS	56	VALVES - FLEXIBLE EXTENSION	81/82
SPRAY ADHESIVE	13	VALVES - METAL EXTENSION	80/81
STAINLESS STEEL RULE	55	VALVES - PLASTIC EXTENSION	80
STATIC WHEEL BALANCERS	98	VALVES - RUBBER EXTENSION	81
STRING SYSTEMS	10	WISE GRIPS	55
STRIPE OFF DISC	60	WASHERS	58
STUD AND BEARING ADHESIVE	13	WASHING UP LIQUID	18
SUPER GLUE	13	WHEEL BALANCING CONES AND ADAPTORS	98
SWING BIN	18	WHEEL BALANCING POWDER	27
SWING BIN LINERS	18	WHEEL BRACES	62/63
TOILET BRUSH SET	18	WHEEL DEGREASER	13
TOILET CLEANER	18	WHEEL MOUNTING FRAME	68
TOILET ROLLS	18	WHEEL SAFETY	85
TOILET SOAP BAR	18	WHEEL SPIDERS	61
TOOL BOX	55	WHEEL WASHERS	99
TORQUE WRENCH ACCESSORIES	47	WHIP HOSE	31
TORQUE WRENCHES	47	WHITE GREASE AEROSOL	13
TPMS ACCESSORIES	73-75	WIRE BRUSH	55
TPMS TOOLS	73	WIRE BRUSH	59
TRACTOR AND EARTHMOVER VALVES	77/78	WIRE CUTTERS	55
TRANSMISSION FLUID	14		
TRAVEL FIRST AID KIT	16		
TRIGGER OIL CAN	56		
TRIGGER SPRAY	55		
TRUCK VALVES	75-77		
TUBE PATCHES	5		
TUBING	41		
TWIST DRILLS	56		
TYRE CLEANER	13		
TYRE COMPRESSION TOOL	93		
TYRE FOAM AEROSOL	13		

CODE	PAGE	CODE	PAGE	CODE	PAGE	CODE	PAGE	CODE	PAGE	CODE	PAGE	CODE	PAGE	CODE	PAGE	CODE	PAGE
000320	11	007140	42	010222	49	012093	29	015590	85	052300	69	153040	6	157054	10	202470	14
002103	29	007200	43	010714	51	012620	17	015600	85	052310	69	153060	6	157056	10	202472	14
003000	17	007220	43	010715	51	012640	17	015660	85	052320	70	153064	6	157060	10	202474	14
003020	17	007300	43	010717	51	012660	17	015702	85	052330	70	153070	6	157080	10	202500	11
003040	17	007320	43	010718	51	013000	59	015722	85	052340	70	153080	6	157100	10	202521	11
004000	36	007400	43	010800	51	013020	59	015760	85	052345	70	153100	6	2-92701	54	202540	12
004010	36	007660	42	010810	51	013034	59	015762	85	052350	70	153120	6	2-92812	54	202570	12
004014	36	007920	42	010814	51	013040	59	015780	85	052370	70	153140	6	2-92817	54	202580	12
004016	36	007932	42	010816	51	013060	59	015782	85	052380	70	153160	6	2-92818	54	202700	12
004020	36	007940	42	010818	51	013080	59	015820	85	052400	69	153170	6	2-92905	54	202750	12
004030	36	008000	44	010820	51	013100	59	015840	85	052420	70	153180	6	2-92906	54	203000	59
004034	36	008020	44	010830	51	013120	59	015860	85	052560	70	153200	6	201000	12	203020	59
004036	36	009000	45	010836	51	014000	61	015880	85	052580	70	153220	6	201010	12	203040	59
004040	36	009002	45	010840	51	014020	61	015900	85	052600	70	153240	6	201020	12	203060	59
004050	36	009020	45	010842	51	014040	61	015920	85	052620	70	153280	6	201040	12	203080	59
004054	36	009040	45	010900	51	014060	61	015960	85	101010	11	153500	7	201060	12	203090	59
004056	36	009080	47	010906	51	014120	61	015980	85	101012	11	153510	7	201080	12	203100	59
004070	37	009100	47	010910	51	014140	61	016100	85	10102	49	153520	7	201110	12	203120	59
004080	36	009110	47	010914	51	014200	61	021010	8	101020	11	153560	7	201130	12	203140	12
004100	36	009120	47	010920	51	014220	61	021020	8	101024	11	153564	7	201140	12	203160	13
004104	36	009140	47	010940	51	014240	61	021022	8	101040	11	153570	7	201160	12	204000	13
004120	36	009500	45	011000	53	014260	61	021040	8	102000	16	153574	7	201180	12	204010	13
004124	36	009520	45	011010	55	014280	61	021060	8	102020	16	153580	7	201182	12	205000	41
004300	36	009540	45	011020	55	014300	61	021080	8	102040	16	153590	7	201187	12	205005	41
004340	37	009560	45	011022	55	014320	61	021220	8	102044	16	153594	7	201190	12	205010	41
004380	37	009600	45	011032	55	015010	17	021240	8	150990	5	153600	7	201195	12	205020	41
004420	37	009620	45	011040	55	015012	17	051000	10	150995	5	153610	7	201200	12	205025	41
004620	37	009640	45	011042	55	015014	17	051001	10	151000	5	154100	6	202000	13	205040	41
004630	37	009725	47	011048	55	015018	17	051020	54	151002	5	154120	6	202020	13	205050	41
004690	37	009732	47	011050	55	015020	85	051022	54	151020	5	154140	6	202030	13	205060	41
004700	37	009740	47	011060	55	015022	85	051040	54	151022	5	154150	6	202040	13	205080	41
005000	32	009760	47	011061	55	015030	85	051060	10	151040	5	154160	6	202044	13	205210	41
005001	32	009780	47	011066	55	015040	85	051070	10	151042	5	154200	6	202060	13	205214	41
005010	32	009910	47	011067	55	015050	85	051080	11	151060	5	154220	6	202100	13	205222	41
005020	32	010002	47	011080	55	015120	11	051100	54	151080	5	154240	6	202110	13	205226	41
005042	32	010004	47	011082	55	015124	11	051110	10	151088	5	154260	6	202114	13	205230	41
005054	32	010020	47	011084	55	015141	11	051120	10	151090	5	154300	6	202120	13	205234	41
005056	32	010026	47	011088	55	015142	11	051140	54	151095	5	154320	6	202140	13	205238	41
005059	32	010030	49	011090	55	015144	11	051150	54	151120	5	154340	6	202160	13	205242	41
005072	32	010042	49	011100	93	015154	11	051160	54	151140	5	154360	6	202165	13	205246	41
005076	32	010050	49	011105	93	015382	85	051170	54	151160	5	154980	7	202170	13	205250	41
005200	32	010060	49	011107	93	015384	85	052000	68	151180	5	155000	7	202172	13	205254	41
005270	33	010062	49	011109	93	015386	85	052060	68	151190	5	155020	7	202174	13	205258	41
005300	33	010064	49	011110	93	015388	85	052100	70	152000	5	155040	7	202176	13	206000	41
005320	33	010100	49	011115	55	015480	85	052120	69	152020	5	155060	7	202180	13	207000	35
005400	33	010110	49	011120	54	015490	85	052124	69	152040	5	155080	7	202220	13	207020	35
005500	36	010120	49	011140	54	015492	85	052132	69	152100	5	155120	7	202262	13	207040	35
005520	36	010122	49	011160	93	015494	85	052140	69	152120	5	155140	7	202270	13	207060	35
005540	36	010126	49	012001	29	015500	85	052160	70	152140	5	155160	7	202300	14	207070	35
005560	36	010128	49	012004	29	015510	85	052220	69	152160	5	157000	8	202406	14	207120	35
005610	36	010130	49	012010	29	015520	85	052230	69	152180	5	157002	8	202410	14	207126	35
005620	36	010202	49	012011	29	015530	85	052240	69	153000	6	157020	8	202421	14	207140	35
005640	36	010211	49	012072	29	015540	85	052250	69	153010	6	157040	8	202430	14	207160	35
006200	98	010212	49	012091	29	015560	85	052260	70	153014	6	157050	10	202440	14	207200	35
007120	42	010216	49	012092	29	015580	85	052280	70	153020	6	157052	10	202452	14	208000	35

CODE	PAGE	CODE	PAGE	CODE	PAGE	CODE	PAGE	CODE	PAGE	CODE	PAGE	CODE	PAGE	CODE	PAGE	CODE	PAGE
208010	35	213000	39	215260	44	218307	60	220240	61	223080	63	224988	64	226580	65	232000	83
208020	35	213020	39	215280	44	218308	60	220260	61	223100	63	224990	64	226600	65	232010	83
208040	35	213030	39	215300	44	218500	31	220280	61	223120	63	224992	64	226610	65	232020	83
208050	35	213040	39	215400	44	218510	31	221005	61	223140	63	224996	64	226620	65	232030	83
208052	35	213050	39	215420	44	218520	31	221010	61	223160	63	225000	64	226640	65	232040	83
208060	35	213060	39	216000	51	218600	31	221020	61	223170	62	225020	64	227000	65	232060	83
208080	35	213200	39	216016	51	218620	31	221030	61	223180	62	225030	64	227010	65	232080	83
208100	35	213220	39	216020	51	218640	31	221040	61	223200	62	225040	64	227020	65	232100	83
208120	35	213240	39	216040	53	218700	31	222012	62	223204	62	225050	64	227040	65	232120	83
208140	36	213500	39	216060	53	218720	31	222016	62	223220	63	225060	64	227050	65	232140	83
208160	36	213510	39	216062	53	218740	31	222020	62	223420	62	225064	64	227060	65	232180	83
208180	35	213520	39	216080	53	218760	31	222030	62	223440	62	225066	64	227080	67	232220	83
208400	35	213540	39	216090	53	218800	32	222040	62	223460	62	225068	64	227090	67	233000	83
208402	35	213550	39	216100	53	218820	32	222046	62	223470	62	225070	64	227100	67	233020	83
209000	37	213560	39	216102	53	219000	59	222050	62	223830	63	225072	64	227110	67	233042	83
209010	37	213600	40	216240	53	219020	59	222060	62	223832	63	225078	64	227120	67	233044	83
209012	37	213602	40	216400	53	219024	59	222066	62	223834	63	225080	64	227140	67	233060	83
209020	37	213604	40	216420	53	219040	59	222080	62	223836	63	225090	64	227180	67	233080	78
209030	37	213610	40	216440	53	219060	59	222100	62	223838	63	225094	64	227184	67	233100	78
209040	37	213612	40	216460	53	219080	59	222110	62	223840	63	225100	64	227190	67	234022	71
209050	37	213614	40	216470	53	219100	59	222120	62	223842	63	225120	64	227200	67	234026	71
209054	37	213616	40	216480	53	219102	59	222140	62	223846	63	225140	64	227220	67	234040	71
209060	38	213618	40	216490	53	219120	60	222160	62	223848	63	225150	64	227230	67	234044	71
209070	38	213622	40	217000	53	219140	60	222170	62	223850	63	225160	64	227240	67	234060	71
209080	38	214000	43	217010	53	219160	60	222180	62	223852	63	225180	64	227280	67	234080	71
209090	38	214020	43	217014	53	219320	60	222190	62	224000	63	225220	64	227300	67	234090	71
210000	39	214040	43	217030	53	219330	60	222200	62	224020	63	225590	64	228000	67	234095	71
210020	39	214060	43	217040	53	219400	60	222220	62	224030	63	225600	64	228020	67	234100	71
210040	39	214080	43	217050	53	219500	60	222300	62	224040	63	225630	64	228040	67	234120	71
210060	39	214100	43	217060	54	219510	60	222310	62	224050	63	225640	64	228050	67	234121	71
211000	38	214200	43	217070	54	220000	60	222330	62	224060	63	225660	64	228060	67	234122	71
211002	38	214220	43	217100	54	220020	60	222336	62	224080	63	225810	65	228070	67	234123	71
211020	38	214240	43	217110	54	220022	60	222340	62	224100	63	225812	65	228080	67	234125	71
211040	38	214260	43	217120	54	220030	60	222346	62	224110	63	225814	65	228500	67	234130	71
211060	38	214280	43	217140	54	220032	60	222350	62	224120	63	225816	65	228520	67	234131	71
211080	38	214420	43	217160	54	220040	60	222360	62	224140	63	226020	64	228540	67	234135	71
211090	38	214440	43	217180	54	220042	60	222380	62	224142	63	226100	65	228560	67	234140	71
211092	38	214460	43	217200	55	220050	60	222400	62	224150	63	226102	65	228700	67	234141	71
211100	38	214480	43	217210	55	220052	60	222420	62	224160	63	226200	68	229000	67	234150	71
211110	38	215000	44	217220	55	220060	60	222440	62	224162	63	226210	68	229010	67	234151	71
211120	38	215020	44	217240	54	220070	60	222460	62	224166	63	226220	68	229100	65	234155	71
211129	38	215040	44	217260	54	220080	60	222470	62	224170	64	226222	68	230000	68	234160	71
211130	38	215057	44	217280	54	220100	60	222480	62	224180	64	226224	68	230010	68	234161	71
211140	38	215060	44	217300	54	220120	60	222500	62	224200	64	226228	68	230020	68	234162	71
211150	38	215100	44	217320	54	220140	61	222520	62	224900	68	226340	45	230040	68	234166	71
211160	38	215120	45	217330	54	220160	61	222540	62	224902	68	226345	45	230100	68	234180	71
211170	39	215140	44	218000	29	220172	61	222560	62	224904	68	226360	45	230200	68	234200	71
211180	39	215142	44	218030	29	220174	61	222580	62	224906	68	226500	65	231000	68	235000	72
211190	39	215150	44	218034	29	220178	61	222600	44	224908	68	226504	65	231010	68	235010	72
211200	39	215155	44	218042	29	220180	61	222620	44	224910	68	226506	65	231020	68	235020	72
211220	39	215160	44	218072	31	220190	61	222640	44	224912	68	226520	65	231030	68	235030	72
212000	38	215180	44	218080	31	220200	61	223000	63	224980	64	226540	65	231040	68	235040	72
212010	38	215200	44	218100	31	220210	61	223020	63	224982	64	226550	65	231100	68	235050	72
212020	38	215220	44	218210	31	220220	61	223040	63	224983	64	226554	65	231120	68	235060	72
212040	38	215240	44	218300	31	220230	61	223060	63	224986	64	226560	65	231200	68	235070	72

CODE	PAGE	CODE	PAGE	CODE	PAGE	CODE	PAGE	CODE	PAGE	CODE	PAGE	CODE	PAGE	CODE	PAGE	CODE	PAGE
235072	72	236324	76	241020	81	244219	17	301060	78	451080	80	601260	79	FB10288	57	FF52160K	58
235080	72	236340	76	241040	81	244220	17	301080	78	451100	79	702000	86	FB10290	57	FF52170K	58
235084	72	236360	76	241060	81	244222	17	301090	78	451120	79	702020	86	FB10291	57	FF52195K	58
235100	72	236380	76	241080	81	244232	17	301100	78	451140	79	702040	86	FB10292	57	FF52210K	58
235120	72	236400	76	241121	81	244234	17	301120	78	451160	79	702060	86	FB10294	57	FF52220K	58
235130	72	236460	76	241122	81	244238	17	301140	78	451180	79	702080	86	FB10320	57	FF52240K	58
235160	72	236500	76	241123	81	244240	17	301160	78	451200	79	702100	86	FB10375	57	FF52260K	58
235170	72	236600	76	241124	81	244241	17	301180	78	451220	79	702120	86	FB11400	57	FF52280	58
235180	72	236620	76	241125	81	244242	16	301200	78	451260	79	702140	86	FB11720	57	FF52300K	58
235182	72	236700	76	241126	81	244243	16	301220	78	501020	81	702160	86	FB12548	57	FF52330K	58
235200	72	236702	76	241127	81	244248	16	301240	78	501040	81	702180	86	FB12610	57	FF52340	58
235220	72	236720	76	241128	82	244250	16	301260	78	501060	81	801000	86	FB13040	57	FF52380	58
235240	72	237000	77	241129	82	244260	16	301280	78	501070	81	801020	86	FB13070	57	FF52405	58
235260	72	237020	77	241131	82	244270	16	301300	78	501080	81	801040	86	FB13080	57	FF52420	58
235280	72	238000	77	241133	82	244271	16	301320	78	501100	81	801060	86	FB13090	57	FF52430	58
235300	72	238010	77	241134	82	244272	16	301340	78	501120	81	801070	86	FB13330	57	FF52440K	58
235320	72	238020	77	241135	82	244274	16	301360	78	502610	82	801080	86	FB13350	57	FF53802K	58
236000	75	238030	77	241136	82	244275	16	301380	78	502670	82	801100	86	FB13360	57	FF53810	58
236020	75	238040	77	241137	82	244280	55	301400	78	502740	82	801120	86	FB13370	57	FF54330K	58
236030	75	238060	77	241260	82	244300	55	301420	78	503000	84	801140	86	FB13390	57	FF54340K	58
236035	75	239040	77	241280	82	244304	55	301440	78	503040	84	801160	86	FB13460	57	FF54350K	58
236036	75	239060	77	242000	82	244310	55	301460	78	503060	84	801180	86	FB13740	57	FF54360K	58
236040	75	239080	77	242020	82	244313	55	301500	78	503080	84	801200	86	FB13760	57	FF54410K	58
236050	75	239200	77	242040	82	244320	55	301520	78	503100	35	801220	86	FB13780	57	FF54420K	58
236060	75	240000	80	242060	82	244336	55	301540	78	503110	36	801240	86	FB14160	57	FF54430	58
236062	75	240020	80	243000	84	244340	16	301560	78	503120	36	801260	86	FB14170	57	FF54440	58
236064	75	240030	80	243010	84	244344	16	301580	78	503122	36	901020	12	FB14180	57	FF54650	58
236070	75	240040	81	243020	84	244360	55	301600	78	503140	36	901030	12	FB14190	57	FF54830K	58
236074	75	240060	81	243026	84	244365	55	301620	78	503160	35	901034	12	FB14200	57	FF54840K	58
236080	75	240080	81	243029	84	244369	55	301640	78	503180	35	901060	12	FB14300	57	FF54850K	58
236100	75	240094	81	243030	84	244380	55	301660	79	503200	35	901080	12	FB16720	57	FF54860	58
236110	75	240100	81	243040	84	244396	55	301680	79	503220	35	FA01130	56	FB16780	57	FF54880	58
236120	75	240120	81	243060	84	244500	55	301820	79	503240	35	FA01140	56	FC24050	42	FF55220	58
236128	76	240139	81	243080	84	244520	56	301840	79	503260	35	FA01160	56	FC24060	42	FF55230	58
236129	76	240140	81	243100	84	244598	56	301860	79	503280	56	FA01700	56	FC24070	42	FF55240	58
236130	76	240144	81	243120	84	244600	56	301880	79	503300	56	FA02220	56	FC24080	42	FF55250	58
236132	76	240150	81	243140	84	244620	56	301900	79	503320	33	FA02250	56	FC24090	42	FF55334K	58
236140	76	240160	80	243160	56	244640	16	301920	79	503360	33	FA05000	56	FD30352	60	FF55335K	58
236160	76	240162	80	243170	56	244700	16	301940	79	504000	61	FA05260	56	FD30372	60	FF55336K	58
236170	76	240180	80	243190	56	244782	17	301960	79	504020	61	FA05280	56	FD30374	60	FF55337K	58
236180	76	240200	80	243200	84	244784	17	301980	80	601000	84	FA05800	56	FD30760	60	FF55350	58
236190	76	240210	80	243210	84	244786	17	302000	79	601010	84	FB01490	57	FD31100	60	FF55360	58
236199	76	240220	80	243300	84	244840	17	401000	78	601020	84	FB03800	57	FD31110	60	FF55370	58
236200	76	240240	80	244000	84	244860	17	401010	77	601040	83	FB04480	57	FD31160	60	FF55380	58
236204	76	240250	80	244004	84	244880	17	401020	78	601050	83	FB04530	57	FD31170	60	FF55390	58
236210	76	240260	80	244010	84	244962	17	401030	78	601060	83	FB04660	57	FD33020	60	FF55700K	58
236220	76	240270	80	244012	84	244964	17	401040	78	601080	83	FB04720	57	FE40300	41	FF55940K	58
236240	76	240280	80	244040	77	244966	17	402000	79	601100	83	FB04990	57	FE40820	41	FF56010K	58
236242	76	240282	80	244050	77	258010	77	402002	79	601120	79	FB10220K	57	FE41920	41	FF56030K	58
236250	76	240300	80	244060	84	258020	77	402004	79	601122	79	FB10230K	57	FE41930	41	FF56040K	58
236260	76	240322	80	244100	84	258030	77	402020	79	601124	79	FB10240K	57	FE41940	41	FF56060K	58
236300	76	240340	80	244160	55	258200	77	451000	80	601140	79	FB10250K	57	FE41950	41	FF56101	58
236310	76	240342	80	244180	55	301000	78	451020	80	601180	79	FB10260K	57	FF51882	58	FF56580	59
236314	76	240360	80	244200	55	301020	78	451040	79	601200	79	FB10270K	57	FF52100K	58	FF56590	59
236320	76	241000	81	244210	55	301040	78	451060	79	601240	79	FB10280K	57	FF52130K	58	FF56760K	59



CODE	PAGE	CODE	PAGE	CODE	PAGE	CODE	PAGE	CODE	PAGE	CODE	PAGE	CODE	PAGE
FF58730	59	H02000	27	MS41E-12V	87	T72-20-015	73	T72-20-525	74	V04120	23	X02080	26
FF59910	59	H02020	27	MS43-1	88	T72-20-016	73	T72-20-545	74	V04140	23	X02100	26
FF59920	59	H02040	27	MS45-1	89	T72-20-024	73	T72-20-546	74	V04160	23	X02120	26
FG60512	13	H03000	27	MS45TL-1	91	T72-20-029	73	T72-20-657	73	V04180	23	X02140	26
FG65400	14	I01020	27	MS45TOP-1	90	T72-20-032	73	T72-20-820	73	W01000	24	X02160	26
FG65510	14	I01040	27	MS48TL-1	92	T72-20-036	73	T72-20-841	73	W01020	24	X02180	26
FG65520	14	I01060	27	MS52A-3	94	T72-20-046	73	T72-20-843	73	W01040	24	X02200	26
FG65700	14	I01120	27	MS54-3	94	T72-20-063	73	T72-20-845	73	W01060	24	X02220	26
FG66080	56	I01140	27	MS55-3	94	T72-20-065	73	T72-20-854	73	W01080	24	X02300	26
FG66120	56	I01160	27	MS606M	95	T72-20-085	73	T72-20-855	74	W01100	24	Z01280	17
FG66160	56	K01000	98	MS60E	96	T72-20-091	73	T72-20-857	74	W01120	24	Z01300	17
FH70950	59	M15011/E	43	MS62E-1	96	T72-20-092	73	T72-20-887	73	W01140	24	Z01310	18
FH74900	57	M15011/ST	43	MS63E-1	97	T72-20-093	73	TPMSDOCK	73	W01160	24	Z01320	18
FK90040	56	M15115	43	MS65-1	97	T72-20-095	73	TPMSTOOLKIT	73	W01180	24	Z01322	18
FK90080	56	M15119	43	MS73-1	98	T72-20-096	73	TPMSVT36	73	W01260	24	Z01340	18
FK92400	53	M2000387	99	MSALIGN92	99	T72-20-201	83	TPMSVT56	73	W02000	24	Z01350	18
FK92410	53	M2001047	98	MSALIGN926	99	T72-20-202	83	U01000	21	W02020	24	Z01360	18
FK94670	13	M2001346	99	MSL850	99	T72-20-384	74	U01020	21	W02040	24	Z01370	18
FK94670	53	M2001353	99	P05000	8	T72-20-401	75	U01040	21	W02060	24	Z01380	18
FK94950	56	M2002253	98	P05020	8	T72-20-424	74	U01060	21	W02080	24	Z01390	18
FK94970	56	M2002415	98	P05070	8	T72-20-436	74	U01080	21	W02100	24	Z01520	18
FK95080	56	M2002743	98	P05100	8	T72-20-437	75	U01100	21	W02120	25	Z01522	18
FX14275	60	M2002993	98	S01000	20	T72-20-438	75	U01120	21	W02140	25	Z01523	18
FX60280	13	M2200277	93	S01020	20	T72-20-440	75	U01140	21	W02160	25	Z01524	18
FX60300	13	M2200556	98	S01040	20	T72-20-442	75	U01160	21	W02180	25	Z01525	18
FX60330	13	M2201411	93	S01060	20	T72-20-443	75	U01180	21	W02200	25	Z01526	18
FX60340	13	M2201645	93	S01080	20	T72-20-444	75	V01000	23	W02220	25	Z01528	18
FX60370	13	M2201659	93	S01100	20	T72-20-445	75	V01020	23	W02300	25	Z01529	18
FX60400	13	M2201716	93	S01120	20	T72-20-447	75	V01040	23	W03000	25	Z01530	18
FX60402	13	M2201717	93	S01140	20	T72-20-448	75	V01060	23	W03020	25	Z01540	18
FX60450	13	M2201894	93	S01160	20	T72-20-449	75	V01080	23	W03040	25	Z01560	18
FX61250	14	M2400820	98	S01180	20	T72-20-453	75	V01100	23	W03060	25	Z01570	18
FX61270	14	M2401189	98	T03000	19	T72-20-454	75	V01120	23	W03080	25	Z01730	18
FX61425	14	M2402266	98	T03020	19	T72-20-459	75	V01140	23	W03100	25	Z01732	18
FX61500	14	M2402711	99	T03040	19	T72-20-460	75	V01160	23	W03120	25	Z01734	18
FX61550	14	M2402737	98	T03060	19	T72-20-462	75	V01180	23	W03140	25	Z01736	18
FX61600	13	M39P	71	T03080	19	T72-20-465	75	V01300	23	W03160	25	Z01737	18
FX61650	14	M40P	71	T03100	19	T72-20-467	74	V03000	20	W03180	25	Z01744	17
FX61740	14	M8-11100369	93	T03120	19	T72-20-469	74	V03020	20	W03300	25	Z01750	18
FX61780	14	MA901	37	T03140	19	T72-20-501	74	V03040	21	W04300	25	Z01760	18
FX90700	56	MC104102005	40	T03160	19	T72-20-502	74	V03060	21	X00500	26	Z01762	18
FX90740	56	MC104102155	40	T03180	19	T72-20-503	74	V03080	21	X00706	26	Z01780	18
FZ60150	59	MC104102205	40	T03200	19	T72-20-504	74	V03100	21	X00710	26	Z01820	18
FZ60160	59	MC104105005	40	T03220	19	T72-20-505	74	V03120	21	X01076	26	Z01840	18
FZ736750K	58	MC104105152	40	T04000	20	T72-20-506	74	V03140	21	X01100	26	Z01860	18
FZ736766	58	MC104105154	40	T04020	20	T72-20-507	74	V03160	21	X01113	26		
FZ74000	59	MC104105155	40	T04040	20	T72-20-508	74	V03180	21	X01120	26		
H01000	27	MC104105205	40	T04060	20	T72-20-510	74	V03200	21	X01130	26		
H01020	27	MLIFT2P2	100	T04080	20	T72-20-511	74	V03220	21	X01135	26		
H01040	27	MLIFT2P4	100	T04100	20	T72-20-513	74	V04000	23	X01200	27		
H01060	27	MLIFT4P2	100	T04120	20	T72-20-514	74	V04020	23	X01220	27		
H01080	27	MPT230	93	T04140	20	T72-20-515	74	V04040	23	X02000	26		
H01100	27	MPT240	93	T04160	20	T72-20-520	74	V04060	23	X02020	26		
H01120	27	MPT250	93	T04180	20	T72-20-521	74	V04080	23	X02040	26		
H01500	27	MS32-1	87	T72-20-007	73	T72-20-522	74	V04100	23	X02060	26		

AUTO4 LIMITED TERMS & CONDITIONS OF SALE

1 Definitions

In these Terms and Conditions of business the following meanings shall apply: "the Company" shall mean Auto 4 Limited "the Customer" shall mean any person or persons, firm or company who buys or agrees to buy goods from the Company.

2 Conditions Applicable

2.1 These Terms and Conditions shall apply to and govern all contracts for the sale of goods or the supply of services or both entered into by the Company. All conditions of the Customer or other terms and conditions or warranties whatsoever whether communicated before or after these Terms and Conditions are excluded from the contract or any variation thereof unless expressly accepted by the Company in writing, and these Terms and Conditions shall be deemed to be incorporated in any quotation received from the Company and the Customer's own conditions shall not be regarded as a counter offer.

2.2 The exercise by the Company of any right pursuant to these Terms and Conditions shall be without prejudice to any other right available to it whether hereunder or under general law.

3 Quotations

3.1 The Customer acknowledges that no contract was entered into in reliance on any representations other than those incorporated in the Company's quotation and these Conditions, and particularly no catalogue or price list shall form part of the contract documents.

3.2 A quotation by the Company shall not constitute an offer and there shall be no binding contract until the Company has accepted an order.

3.3 Unless otherwise specifically stated, all prices quoted by the Company are exclusive of VAT, which shall be due at the rate in force on the date of the Company's invoice to the Customer.

4 Delivery

4.1 Delivery dates and times specified by the Company are approximate only. Unless expressly agreed by the Company in writing, time for delivery is not and shall not be deemed to be of the essence of the contract. The Customer shall make all arrangements necessary to take delivery of goods whenever they are tendered for delivery.

4.2 If goods are sold and delivered to the Customer in instalments each delivery shall constitute a separate contract, and failure by the Company to deliver any one or more of the instalments or any claim by the Customer in respect of any one or more instalments shall not entitle the Customer to treat the contract as a whole as repudiated.

4.3 All shortages must be reported to Auto 4 Ltd within 3 days of delivery.

4.4 All non deliveries must be reported to Auto 4 Ltd within 21 days of order.

4.5 Please refer to Auto 4 Ltd returns policy if you wish to return goods.

5 Cancellation and Variation

5.1 No cancellation, suspension or variation by the Customer of any order accepted by the Company shall be valid unless agreed by the Company in writing and such agreement may only be given on terms which compensate the Company for any loss, costs, damages, charges and expenses thereby incurred by the Company, such compensation to be decided by the Company in its absolute discretion.

6 The Price and Payment

6.1 The price to be paid by the Customer shall be the sum(s) shown by the Company's invoice(s). This price shall be based on the sum quoted to the Customer, but may be adjusted to reflect any material changes in manufacturing and raw material costs, transport and fuel costs, additional costs imposed by suppliers and changes in import and export or other duties and taxes.

6.2 Payment of the price and VAT shall be due within 30 days of the date of the

Company's invoice unless a different time for payment is specifically agreed between the parties in writing. Time for payment shall be of the essence and payment must be made without setoff or credit unless the same is for a liquidated amount which has been agreed in writing by the Company.

6.3 All other sums due to the Company from the Customer are payable on demand.

6.4 Where goods are delivered in instalments the Company may invoice each instalment separately and the Customer shall pay such invoices in accordance with these Terms and Conditions.

6.5 If the Customer is in default in paying any sum as and when it becomes due, the Company shall have the right to suspend all further deliveries until the default is made good and/or to cancel the contract so far as any goods remain to be delivered thereunder.

6.6 In the event that the Customer fails to pay any monies by the due date, all sums payable by the Customer to the Company shall become immediately due and owing.

6.7 The Company shall charge interest and recovery fees on all overdue monies pursuant to the Late Payment of Commercial Debts (Interest) Act 1998 and Regulations made thereunder. In addition the Company reserves the right in its absolute discretion to recharge preferential discounts previously agreed on orders should payment not be made by the due date. The customer shall also indemnify the Company against expenditure on all costs of recovery including without limitation legal fees, costs and disbursements reasonably incurred. Any banking charges incurred by the Company in respect of dishonoured cheques will be payable by the Customer.

6.8 The Company shall have a general lien on all and any goods for the time being under its control belonging to the Customer for all sums due and for all claims of every description by the Company against the Customer in respect of any order or account and if any sum or sums remain owing to the Company 14 days after the Customer has been given notice in writing of the exercise of such lien the Company shall have the power to sell the whole or any part of such goods to discharge the same sums and claims and all expenses incurred in connection with the sale of the goods and any balance of the proceeds of such sale shall be paid by the Company to the Customer.

6.9 The Customer shall not in any event, until all monies due have been paid to the Company, be entitled to pledge, or in any way charge by way of security for any reason, any of the goods which remain the property of the Company, but if the Customer does so all monies due to the Customer shall become immediately due and payable without prejudice to any other right or remedy of the Company.

7 Title and Risk

7.1 The risk in goods sold to the Customer shall pass to the Customer upon tender for delivery so that the Customer is responsible for all loss damage or deterioration of the goods or a part thereof at the time of the tender if the Customer wrongfully fails to take delivery of the goods when tendered or from the time when the same leave the premises of the Company (or the premises where the same were stored for or by the Company or to the Customer's order) save that if the goods are sold "ex works" and are not collected by the Customer by the due date for collection the goods shall be at the sole risk of the Customer thereafter. Where the goods are delivered by carrier any claims for loss or damage in transit must be made by the Customer against the carrier in accordance with any terms and conditions of business of the carrier.

7.2 Title in any goods which are the subject of a contract for sale between the Company and the Customer shall only pass to the Customer when payment in full for all goods whatsoever supplied and all services rendered at any time by the Company has been made.

8 Insolvency

If any distress or execution shall be levied on the Customer's property or assets or any part thereof, or if the Customer shall make or offer to make any arrangement or composition with its creditors generally or if the Customer:-
(a) being an individual, commits any act of bankruptcy or if any Petition or Receiving Order in Bankruptcy shall be presented or made against him; or
(b) being a partnership, if the said partnership is dissolved for whatsoever reason or if any partner commits any act of bankruptcy or if any Petition or Receiving Order in Bankruptcy shall be presented or made against any partner or the partnership; or
(c) being a limited company, if proceedings are commenced for the liquidation of the Customer or if a meeting of creditors is called pursuant to Section 588 of the Companies Act 1985 or if a resolution is passed for the voluntary winding up of the Customer (other than a members voluntary winding up for the purpose of amalgamation or reconstruction only) or the appointment of an Administrator or if a Receiver is appointed of all or any of the assets of the Customer, or the Customer ceases, or threatens to cease, to carry on business then the Company shall have the right forthwith to determine all subsisting contracts whether remaining to be performed in whole or in part by serving written notice of such determination on the Customer, and all monies due to the Company shall become immediately due and payable.

9 Warranty

Subject as expressly provided in these Conditions and except where goods are sold or services provided to a person dealing as consumer within the meaning of the Unfair Contract Terms Act 1977 all warranties, conditions or other terms implied by statute or common law are excluded to the fullest extent permissible by law.

10 Restriction of Liability

10.1 In cases where a valid claim is based on any defect in the quality or condition of goods or their failure to correspond with specification (if any) and the claim is notified to the Company in accordance with clause 10.2, the Company shall be entitled to replace the goods or any part in question free of charge or, at the Company's sole discretion, to refund to the Customer the price of the goods, but the Company shall have no further liability to the Customer.

10.2 No liability shall attach to the Company unless details of a defect are notified to the Company in writing within 7 days of the date of delivery of the goods, or the date of the event giving rise to such loss if it is not apparent upon the date of delivery. In cases of alleged non delivery, claims must be notified to the Company within 7 days of despatch of the goods by the Company.

10.3 For the avoidance of doubt, nothing in this agreement shall confer on any third party any benefit or the right to enforce any term of this agreement.

11 Events Outside Control

The Company shall not be liable to the Customer or be deemed to be in breach of contract by reason of any delay in performing, or any failure to perform, any of the Company's obligations in relation to the goods, if the delay or failure was due to any cause beyond the Company's reasonable control, including strikes, lockout, labour disturbances, fire, accidents, breakdowns, shortages of supply, statutory or government order, prohibition, adverse weather conditions, acts of god, war, hostilities, civil disturbance, or any other cause of whatsoever nature beyond the control of the Company.

12 Applicable Law

These Terms and Conditions and the rights and obligations of the parties to the contract shall be governed, interpreted and construed solely in accordance with the Laws of England.

Our price promise:

The promise "If you can find the same product cheaper elsewhere we will refund the difference"

The conditions;

- * the alternative product has to be available for purchase
- * the alternative product has to be of comparable quality
- * where a product is branded the alternative product has to be of the same brand
- * where appropriate the standards of service and support need to be identical (e.g. where prices include additional services, such as equipment sales)
- * proof of alternative product pricing must be provided in the form of a current invoice
- * refund only available within 28 days of purchase

Auto4, supplying professional brands at competitive prices to the automotive market

Exceptional Auto4 Value

The range and quality of products we supply together with the very high levels of customer service go along way towards delivering real value for money. However, in addition to this we also carefully and constantly monitor prices in the market to ensure it is not only our service and products that are market leading but our prices to.



Auto4 Price Promise**

If you can find the same product cheaper elsewhere we'll refund the difference!



FREE Next Day Delivery *

This couldn't be more straightforward, for all orders received before 4pm we deliver next day free of charge*

*(minimum order value of £60 applies. This is not always possible at busy times during the month).

Payment



We accept the following payment methods:

- Cheques (Subject to card limit)
- Credit card (All major cards accepted)
- Debit card

Cheques : Payable to 'Auto4 Limited'.

How to Order from Auto4

We have a variety of ways to order from Auto4;

- our field sales representatives are nationally based, they carry stock and will happily visit you at a time to suit your requirements
- for those customers who do not want a sales representative to call but want to be prompted our tele-sales department are happy to oblige. This team will contact you at a time convenient to you to discuss your product needs and process orders on your behalf
- our sales support team are always on hand to help whether you want to place an order, have a technical query or you have simply lost the telephone number of your local field sales representative
- if you want the ease, convenience and control of placing orders online you can also do this by visiting the Auto4 website which can be found at www.auto4.co.uk, this is available 24 hours a day 365 days a year
- alternatively you can fax our sales office on 01623 721950 or email us at sales@auto4.co.uk

To discuss all or any of the above ordering options please contact our sales support team on 0845 0770 190.

To help us to help you, for the fastest possible and most accurate processing of your order it is best if when you contact us you have your account number, purchase order number and product reference numbers.

Orderline : 0845 0770 190

Lines Open: 8.30am - 5.00pm Monday - Friday or Email: sales@auto4.co.uk

or buy online at : www.auto4.co.uk

AUTO4

EQUIPPING THE TYRE INDUSTRY

** The alternative product has to be available for purchase. The alternative product has to be of comparable quality. Where a product is branded the alternative product has to be of the same brand. Where appropriate the standards of service and support need to be identical (e.g. where prices include additional services, such as equipment sales). Proof of alternative product pricing must be provided in the form of a current invoice. Refund only available within 28 days of purchase.



5,000^{stocked} consumables



**OUR PRICE
PROMISE**



If you find the same product
cheaper elsewhere we will
refund the difference! **

Orderline : 0845 0770 190

Lines Open: 8.30am - 5.00pm Monday - Friday or Email: sales@auto4.co.uk

or buy online at : www.auto4.co.uk

Auto4 Ltd, Unit 4a, Park Lane Business Court, Park Lane, Kirkby in Ashfield, Nottinghamshire, NG17 9GU.

All product information, descriptions and specifications correct at time of print and are subject to change without prior notification. Omissions not admitted.
Copyright Auto4 2018. All rights reserved. Edition 5.